

# M37103M4-XXXSP

**SINGLE-CHIP 8-BIT CMOS MICROCOMPUTER for VOLTAGE SYNTHESIZER  
with ON-SCREEN DISPLAY CONTROLLER**

## DISCRIPTION

The M37103M4-XXXSP is a single-chip microcomputer designed with CMOS silicon gate technology. It is housed in a 64-pin shrink plastic molded DIP. This single-chip microcomputer is useful for the high-tech channel-selection system for TVs.

In addition to its simple instruction set, the ROM, RAM, and I/O addresses are placed on the same memory map to enable easy programming.

## FEATURES

- Number of basic instructions..... 69
- Memory size
  - ROM ..... 8192 bytes
  - RAM..... 192 bytes
- Instruction execution time
  - ..... 2 $\mu$ s (minimum instructions at 4MHz frequency)
- Single power supply.....5V $\pm$ 10%
- Power dissipation
  - normal operation mode (at 4MHz frequency)
    - ..... 35mW (V<sub>CC</sub>=5V, Typ.)
- Subroutine nesting ..... 96levels (Max.)
- Interrupt..... 8types, 5vectors
- 8-bit timer..... 4
- Programmable I/O ports
  - (Ports P0, P1, P2, P3, P4, P5, P6)..... 46
- Serial I/O (8-bit) ..... 1
- PWM function ..... 14-bit $\times$ 1
  - ..... 8-bit $\times$ 4
  - ..... 6-bit $\times$ 6
- Comparator ..... 1
- Generating function for clock input of EAROM
- Two clock generating circuits
  - (one is for main clock, the other is for clock function)
- 63-Character on screen display function
  - Number of character..... 21 characters $\times$ 3 lines
  - Kinds of character..... 96

## PIN CONFIGURATION (TOP VIEW)

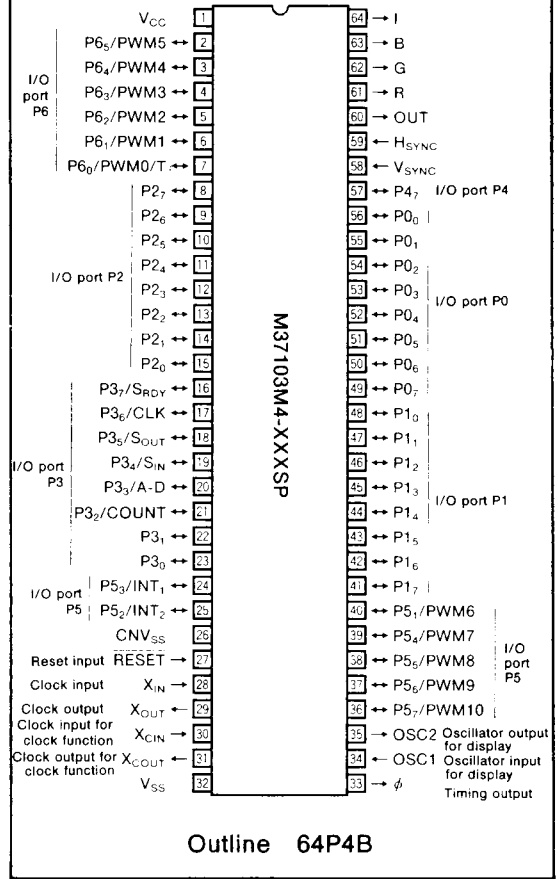

## APPLICATION

TV

**SINGLE-CHIP 8-BIT CMOS MICROCOMPUTER for VOLTAGE SYNTHESIZER**  
 with **ON-SCREEN DISPLAY CONTROLLER**

**M37103M4-XXXSP BLOCK DIAGRAM**

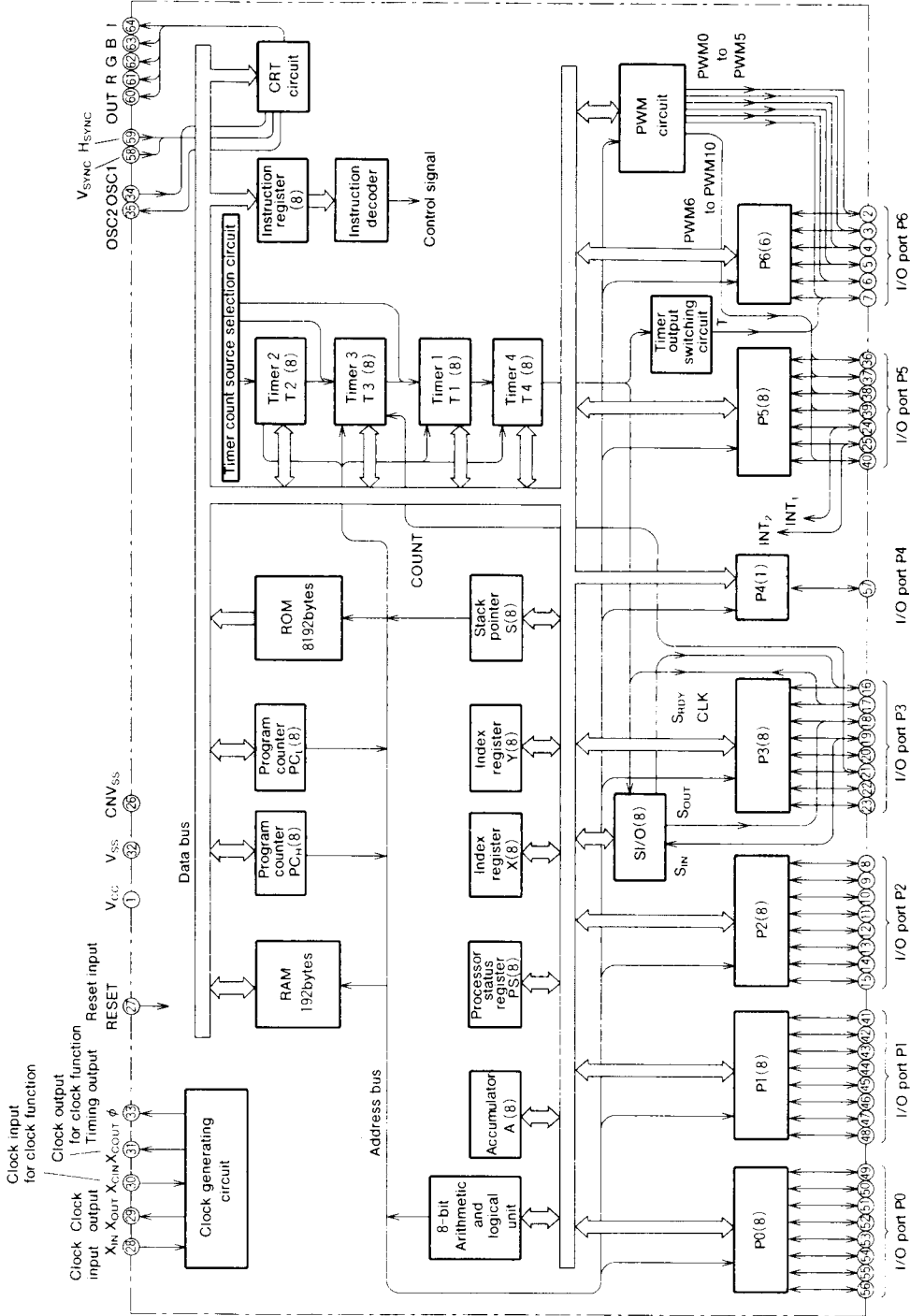

**SINGLE-CHIP 8-BIT CMOS MICROCOMPUTER for VOLTAGE SYNTHESIZER  
with ON-SCREEN DISPLAY CONTROLLER**

**FUNCTIONS OF M37103M4-XXXSP**

Parameter		Functions	
Number of basic instructions		69	
Instruction execution time		2 $\mu$ s (minimum instructions, at 4MHz frequency)	
Clock frequency		4MHz	
Memory size	ROM	8192bytes	
	RAM	192bytes	
Input/Output ports	P0	I/O 8-bitX1 (middle-voltage N-channel open drain)	
	P1, P2	I/O 8-bitX2	
	P3	I/O 8-bitX1	
	P4 <sub>7</sub>	I/O 1-bitX1	
	I, B, R, G, OUT	Output 1-bitX5 (for CRT display)	
	V <sub>SYNC</sub> , H <sub>SYNC</sub>	Input 1-bitX2 (for CRT display)	
	P5 <sub>2</sub> , P5 <sub>3</sub>	I/O 2-bitX1 (can be used as an input for either INT <sub>2</sub> or INT <sub>1</sub> )	
	P5 <sub>1</sub> , P5 <sub>4</sub> -P5 <sub>7</sub>	I/O 5-bitX1 (middle-voltage N-channel open drain)	
	P6 <sub>0</sub> , P6 <sub>1</sub>	I/O 2-bitX1	
P6 <sub>2</sub> -P6 <sub>5</sub>		I/O 4-bitX1 (middle-voltage N-channel open drain)	
Serial I/O		8-bitX1	
Timers		8-bit timerX4	
Subroutine nesting		96levels (max)	
Interrupt		Two external interrupts, three internal timer interrupts (or timerX2, serial I/OX1, CRTX1)	
Clock generating circuit		Two built-in circuits (externally connected ceramic or quartz crystal oscillator)	
Supply voltage		5V $\pm$ 10%	
Power dissipation	at high-speed operation	CRT display function ON	35mW (clock frequency X <sub>IN</sub> =4MHz, f <sub>CR</sub> =6MHz)
		CRT display function OFF	20mW (clock frequency X <sub>IN</sub> =4MHz)
	at low-speed operation	CRT display function OFF	0.3mW (clock frequency X <sub>CIN</sub> =32kHz)
			I <sub>CC</sub> =1 $\mu$ A (when clock is stopped)
Input/Output characteristics	Input/Output voltage	12V (P0, P5 <sub>1</sub> , P5 <sub>4</sub> -P5 <sub>7</sub> , P6 <sub>2</sub> -P6 <sub>5</sub> : input/output, RESET, CNV <sub>SS</sub> : input -0.3 to V <sub>CC</sub> +0.3V (P1, P2, P3, P4, P5 <sub>2</sub> , P5 <sub>3</sub> , P6 <sub>0</sub> , P6 <sub>1</sub> )	
	Output current	0.5mA (P0, P1, P2, P3, P5, P6 <sub>2</sub> -P6 <sub>5</sub> : N-channel open drain input/output 0.5mA, -0.5mA (P4) : CMOS input-output, R, G, B, I, OUT, P6 <sub>0</sub> -P6 <sub>1</sub> : CMOS output	
Operating temperature range		-10 to 70°C	
Device structure		CMOS silicon gate process	
Package		64-pin shrink plastic molded DIP	
CRT display function	Number of character	21 charactersX3 lines	
	Kinds of character	96 (12X16 dots)	

**SINGLE-CHIP 8-BIT CMOS MICROCOMPUTER for VOLTAGE SYNTHESIZER  
with ON-SCREEN DISPLAY CONTROLLER**

**PIN DESCRIPTION**

Pin	Name	Input/ Output	Functions
V <sub>CC</sub> , V <sub>SS</sub>	Supply voltage		Power supply inputs 5V±10% to V <sub>CC</sub> and 0V to V <sub>SS</sub> .
CNV <sub>SS</sub>	CNV <sub>SS</sub>		This is connect to V <sub>SS</sub> .
RESET	Reset input	Input	To enter the reset state, the reset input pin must be kept at a "L" for more than 2μs (under normal V <sub>CC</sub> conditions). If more time is needed for the crystal oscillator to stabilize, this "L" condition should be maintained for the required time.
X <sub>IN</sub>	Clock input	Input	These are I/O pins of internal clock generating circuit for main clock. To control generating frequency, an external ceramic or a quartz crystal oscillator is connected between the X <sub>IN</sub> and X <sub>OUT</sub> pins and external condensers are connected. If an external clock is used, the clock source should be connected the X <sub>IN</sub> pin and the X <sub>OUT</sub> pin should be left open.
X <sub>OUT</sub>	Clock output	Output	
φ	Timing output	Output	This is the timing output pin. In single-chip mode, the output can be controlled by selecting the option.
X <sub>CIN</sub>	Clock input for clock function	Input	This is the I/O pins of the clock generating circuit for the clock function. To control generating frequency, an external ceramic or a quartz crystal oscillator is connected between the X <sub>CIN</sub> and X <sub>COOUT</sub> pins and external condensers are connected. If an external clock is used, the clock source should be connected to the X <sub>CIN</sub> pin and the X <sub>COOUT</sub> pin should be left open. This clock can be used as a program controlled the system clock.
X <sub>COOUT</sub>	Clock output for clock function	Output	
P0 <sub>0</sub> -P0 <sub>7</sub>	I/O port P0	I/O	Port P0 is an 8-bit I/O port with directional registers allowing each I/O bit to be individually programmed as input or output. At reset, this port is set to input mode. The output structure is middle-voltage N-channel open drain.
P1 <sub>0</sub> -P1 <sub>7</sub>	I/O port P1	I/O	Port P1 is an 8-bit I/O port and has basically the same functions as port P0. It can be built in pull-up transistor at each pin by selecting the option.
P2 <sub>0</sub> -P2 <sub>7</sub>	I/O port P2	I/O	Port P2 is an 8-bit I/O port and has basically the same functions as port P1.
P3 <sub>0</sub> -P3 <sub>7</sub>	I/O port P3	I/O	Port P3 is an 8-bit I/O port and has basically the same functions as port P0, but the output structure is N-channel open drain. When serial I/O is used, P3 <sub>0</sub> , P3 <sub>6</sub> , P3 <sub>5</sub> , and P3 <sub>4</sub> work as S <sub>RDY</sub> , CLK, S <sub>OUT</sub> , and S <sub>IN</sub> pins, respectively. P3 <sub>3</sub> works as an analog input for comparator and P3 <sub>2</sub> works as a counter input.
P4 <sub>7</sub>	I/O port P4 <sub>7</sub>	I/O	Port P4 <sub>7</sub> is a 1-bit I/O port and has basically the same functions as port P0, but the output structure is CMOS output.
I, B, G, R, OUT	CRT output	Output	This is a 5-bit output pin for CRT display. The output polarity can be changed by selecting the option. At reset, inactive polarity is selected. The output structure is CMOS output.
H <sub>SYNC</sub>	H <sub>SYNC</sub> input	Input	This is the horizontal synchronizing signal input for CRT display. The input polarity can be changed by selecting the option.
V <sub>SYNC</sub>	V <sub>SYNC</sub> input	Input	This is the vertical synchronizing signal input for CRT display. The input polarity can be changed by selecting the option.
P5 <sub>2</sub> , P5 <sub>3</sub>	I/O port P5	I/O	These ports have basically the same function as ports P3, and are in common with interrupt input pins.
P5 <sub>1</sub> , P5 <sub>4</sub> -P5 <sub>7</sub>			These ports have basically the same function as port P0, and can be programmed to function as PWM output pins.
P6 <sub>0</sub> -P6 <sub>5</sub>	I/O port P6	I/O	Port P6 is a 6-bit I/O port and has basically the same functions as port P0. The output structure of P6 <sub>0</sub> , P6 <sub>1</sub> is CMOS output and the output structure of P6 <sub>2</sub> -P6 <sub>5</sub> is middle-voltage N-channel open drain. This port can be programmed to function as PWM output pins. Also P6 <sub>0</sub> is in common with timer output pin (T <sub>1</sub> ).
OSC1, OSC2	Clock input for CRT display Clock output for CRT display	Input Output	This is the I/O pins of the clock generating circuit for the CRT display function. To control generating frequency, external condensers and resistors are connected.

**SINGLE-CHIP 8-BIT CMOS MICROCOMPUTER for VOLTAGE SYNTHESIZER  
with ON-SCREEN DISPLAY CONTROLLER**

**FUNCTIONAL DESCRIPTION  
Central Processing Unit (CPU)**

The M37103 microcomputers use the standard MELPS 740 instruction set. For details of instructions, refer to the MELPS 740 CPU core basic functions, or the MELPS 740 Software Manual.

Machine-resident instructions are as follows:

The FST and SLW instructions are not provided.

The MUL and DIV instructions are not provided.

The WIT instruction can be used.

The STP instruction can be used.

**MEMORY**

• **Special Function Register (SFR) Area**

The special function register (SFR) area contains the registers relating to functions such as I/O ports and timers.

• **RAM**

RAM is used for data storage as well as a stack area.

• **ROM**

ROM is used for storing user programs as well as the interrupt vector area.

• **RAM for display**

RAM for display is used for specifying the character codes and colors to display.

• **Interrupt Vector Area**

The interrupt vector area is for storing jump destination addresses used at reset or when an interrupt is generated.

• **Zero Page**

Zero page addressing mode is useful because it enables access to this area with fewer instruction cycles.

• **Special Page**

Special page addressing mode is useful because it enables access to this area with fewer instruction cycles.

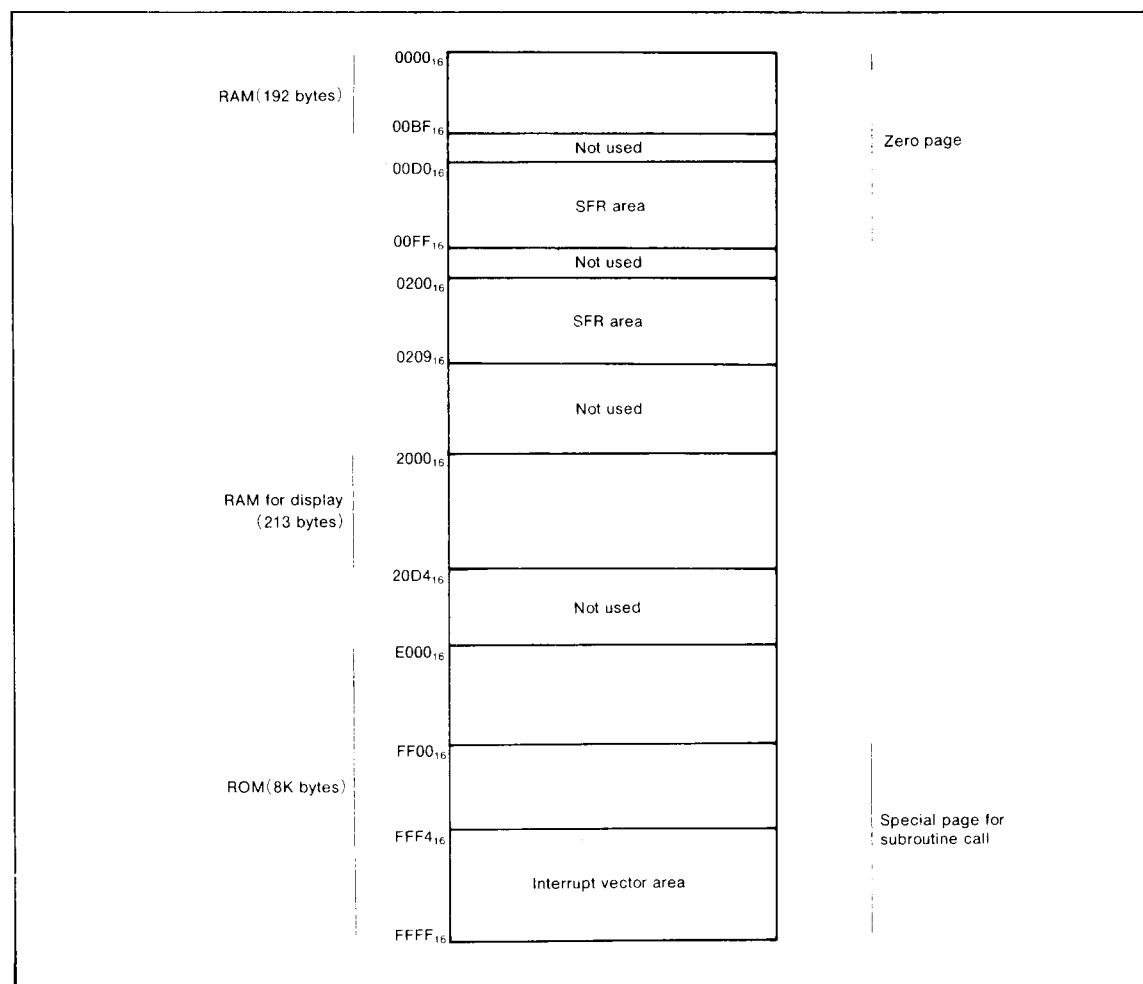

**SINGLE-CHIP 8-BIT CMOS MICROCOMPUTER for VOLTAGE SYNTHESIZER  
with ON-SCREEN DISPLAY CONTROLLER**

00D0 <sub>16</sub>	Horizontal position register
00D1 <sub>16</sub>	Vertical position register of block 1
00D2 <sub>16</sub>	Vertical position register of block 2
00D3 <sub>16</sub>	Vertical position register of block 3
00D4 <sub>16</sub>	Color register 0
00D5 <sub>16</sub>	Color register 1
00D6 <sub>16</sub>	Color register 2
00D7 <sub>16</sub>	Color register 3
00D8 <sub>16</sub>	Display control register
00D9 <sub>16</sub>	Display block counter
00DA <sub>16</sub>	
00DB <sub>16</sub>	
00DC <sub>16</sub>	
00DD <sub>16</sub>	
00DE <sub>16</sub>	
00DF <sub>16</sub>	
00E0 <sub>16</sub>	Port P0
00E1 <sub>16</sub>	Port P0 directional register
00E2 <sub>16</sub>	Port P1
00E3 <sub>16</sub>	Port P1 directional register
00E4 <sub>16</sub>	Port P2
00E5 <sub>16</sub>	Port P2 directional register
00E6 <sub>16</sub>	
00E7 <sub>16</sub>	A-D control register
00E8 <sub>16</sub>	Port P3
00E9 <sub>16</sub>	Port P3 directional register
00EA <sub>16</sub>	Port P4
00EB <sub>16</sub>	Port P4 directional register
00EC <sub>16</sub>	Port P5
00ED <sub>16</sub>	Port P5 directional register
00EE <sub>16</sub>	Port P6
00EF <sub>16</sub>	Port P6 directional register
00F0 <sub>16</sub>	PWM1-H register
00F1 <sub>16</sub>	PWM1-L register
00F2 <sub>16</sub>	PWM2 register
00F3 <sub>16</sub>	PWM3 register
00F4 <sub>16</sub>	PWM4 register
00F5 <sub>16</sub>	PWM control register
00F6 <sub>16</sub>	Serial I/O mode register
00F7 <sub>16</sub>	Serial I/O register
00F8 <sub>16</sub>	PWM5 register
00F9 <sub>16</sub>	PWM output control register
00FA <sub>16</sub>	Timer 1
00FB <sub>16</sub>	Interrupt control register 2
00FC <sub>16</sub>	Timer 2
00FD <sub>16</sub>	Timer 3
00FE <sub>16</sub>	Interrupt control register 1
00FF <sub>16</sub>	Timer control register
0100 <sub>16</sub>	
01FF <sub>16</sub>	
0200 <sub>16</sub>	PWM0 register
0201 <sub>16</sub>	PWM6 register
0202 <sub>16</sub>	PWM7 register
0203 <sub>16</sub>	PWM8 register
0204 <sub>16</sub>	PWM9 register
0205 <sub>16</sub>	PWM10 register
0206 <sub>16</sub>	PWM output control register
0207 <sub>16</sub>	
0208 <sub>16</sub>	Timer 4 control register
0209 <sub>16</sub>	Timer 4

Fig. 2 SFR (Special Function Register) memory map

**SINGLE-CHIP 8-BIT CMOS MICROCOMPUTER for VOLTAGE SYNTHESIZER  
with ON-SCREEN DISPLAY CONTROLLER**

**INTERRUPTS**

Interrupts can be caused by 8 different events consisting of two external, five internal, and one software event.

Interrupts are vectored interrupts with priorities shown in Table 1. Reset is also included in the table because its operation is similar to an interrupt.

When an interrupt is accepted, the registers are pushed, interrupt disable flag I is set, and the program jumps to the address specified in the vector table. The interrupt request bit is cleared automatically. The reset and BRK instruction interrupt can never be disabled. Other interrupts are disabled when the interrupt disable flag is set.

Falling edge active or rising edge active can be selected for each of the INT<sub>1</sub> and INT<sub>2</sub> external interrupts selected by bits 4 and 5 of the PWM control register. Whether the INT<sub>1</sub> external interrupt or the CRT display is to be accepted can be selected by bit 0 of interrupt control register 2.

Whether the timer 1 or serial I/O interrupt is to be accepted can be selected by bit 2 of the serial I/O mode register.

All interrupts except the BRK instruction interrupt have an interrupt request bit and an interrupt enable bit. The interrupt request bits and the interrupt enable bits are in interrupt control register 1 and timer control register. Figure 3 shows the structure of the interrupt control registers 1 and 2 and timer control register.

Interrupts other than the BRK instruction interrupt and reset are accepted when the interrupt enable bit is "1", interrupt request bit is "1", and the interrupt disable flag is "0". The interrupt request bit can be clear with a program, but not set. The interrupt enable bit can be set and clear with a program.

Reset is treated as a non-maskable interrupt with the highest priority. Figure 4 shows interrupts control.

Table 1. Interrupt vector address and priority.

Event	Priority	Vector addresses	Remarks
RESET	1	FFFF <sub>16</sub> , FFFE <sub>16</sub>	Non-maskable
INT <sub>1</sub> or CRT display interrupt	2	FFFD <sub>16</sub> , FFFC <sub>16</sub>	INT <sub>1</sub> external interrupt (phase programmable)
Timer 3 interrupt	3	FFFB <sub>16</sub> , FFFA <sub>16</sub>	
Timer 2 interrupt	4	FFF9 <sub>16</sub> , FFF8 <sub>16</sub>	
Timer 1 or serial I/O interrupt	5	FFF7 <sub>16</sub> , FFF6 <sub>16</sub>	
INT <sub>2</sub> interrupt (BRK instruction interrupt)	6	FFF5 <sub>16</sub> , FFF4 <sub>16</sub>	INT <sub>2</sub> external interrupt (phase programmable) BRK instruction interrupt (non-maskable software interrupt)

**SINGLE-CHIP 8-BIT CMOS MICROCOMPUTER for VOLTAGE SYNTHESIZER  
with ON-SCREEN DISPLAY CONTROLLER**

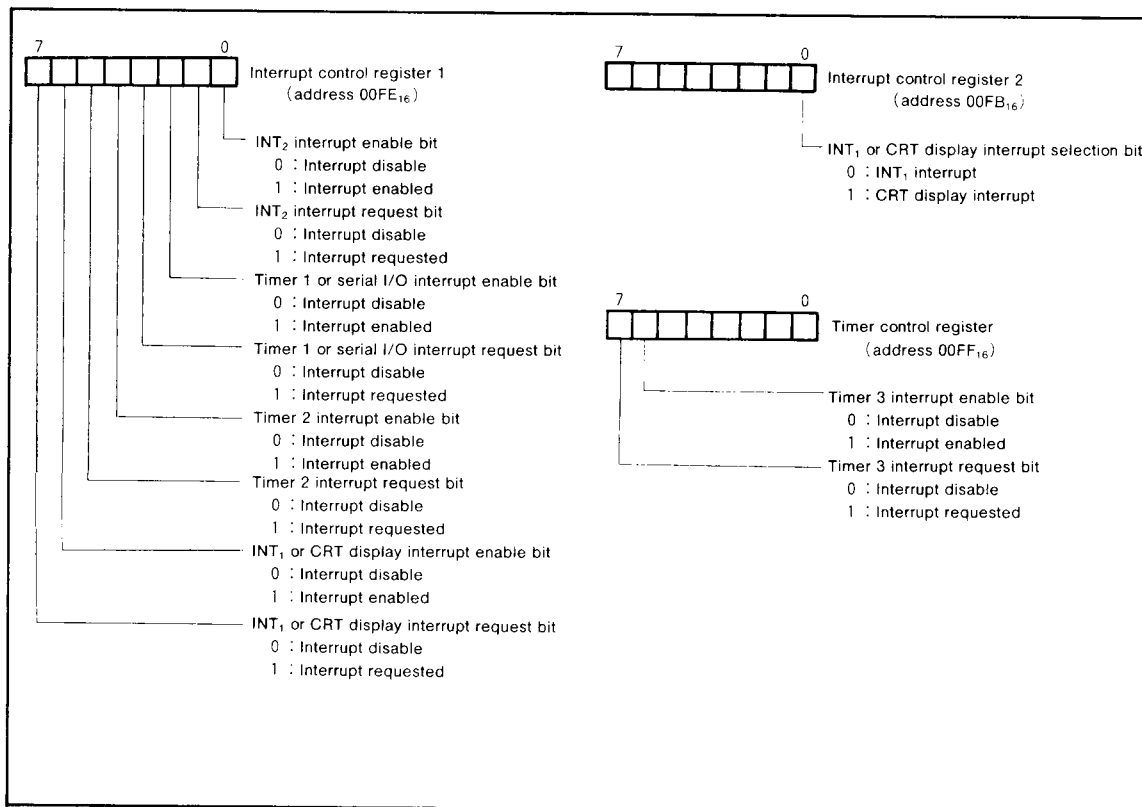

Fig. 3 Structure of registers related to interrupt

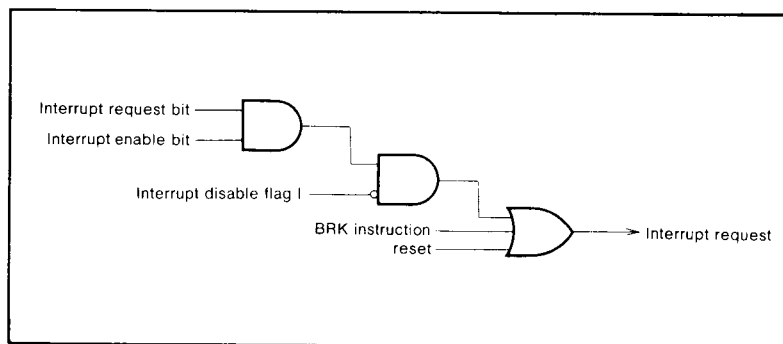

Fig. 4 Interrupt control



**SINGLE-CHIP 8-BIT CMOS MICROCOMPUTER for VOLTAGE SYNTHESIZER  
with ON-SCREEN DISPLAY CONTROLLER**

---

## TIMER

The M37103M4-XXXSP has four timers; timer 1, timer 2 timer 3, timer 4.

A block diagram of timer 1 through 3 is shown in Figure 5 and a block diagram of timer 4 is shown in Figure 6. The count source for timer 1 through 3 can be selected by using bit 2, 3, 4 of the timer control register (address  $00FF_{16}$ ), as shown in Figure 7. Timer 1 through 3 are down count timers and have 8-bit latches. When a timer reaches "0" and the next count pulse is input to a timer, the contents of the re-load latch are loaded into the timer. The division ratio of the timer is  $1/(n+1)$ , where  $n$  is the contents of timer latch.

Timer 1 through 3 has interrupt generating functions. The timer interrupt request bit which is in the interrupt control register 1 or timer control register (located at addresses  $00FE_{16}$  and  $00FF_{16}$  respectively) is set at the next count pulse after the timer reaches "0" (see interrupt section).

The starting and stopping of timer 2 is controlled by bit 5 of the timer control register 2. If the bit 5 is "0", the timer starts counting, and the bit 5 is "1", the timer stops.

The count source of timer 4 can be selected by bit 0 and bit 1 of timer 4 control register (address  $0208_{16}$ ). When bit 0 and bit 1 are set to (00) or (11), timer 4 stop counting. The structure of timer 4 control register is shown in Figure 8.

Timer 4 has auto-reload register. The auto-reload register can be written by writing a data to timer 4 register. A data written to the auto-reload register is set to counter by setting bit 4 of timer 4 control register. And by reading a data from timer 4 register, the value of counter can be read.

When timer 4 is overflow, timer 4 overflow flag is set and the content of auto-reload register are loaded into the counter.

At a reset or stop mode,  $FF_{16}$  is automatically set in timer 2 and  $07_{16}$  in timer 3.

After a STP instruction is executed, timer 3, timer 2, and the clock ( $\phi$  divided by 4) are connected in series (regardless of the status of bit 2 through 4 of the timer control register). This state is canceled if timer 3 interrupt request bit is set to "1", or if the system is reset. Before the STP instruction is executed, bit 5 of the timer control register (timer 2 count stop bit) must be set to "0". For more details on the STP instruction, refer to the oscillation circuit section.

**SINGLE-CHIP 8-BIT CMOS MICROCOMPUTER for VOLTAGE SYNTHESIZER  
 with ON-SCREEN DISPLAY CONTROLLER**

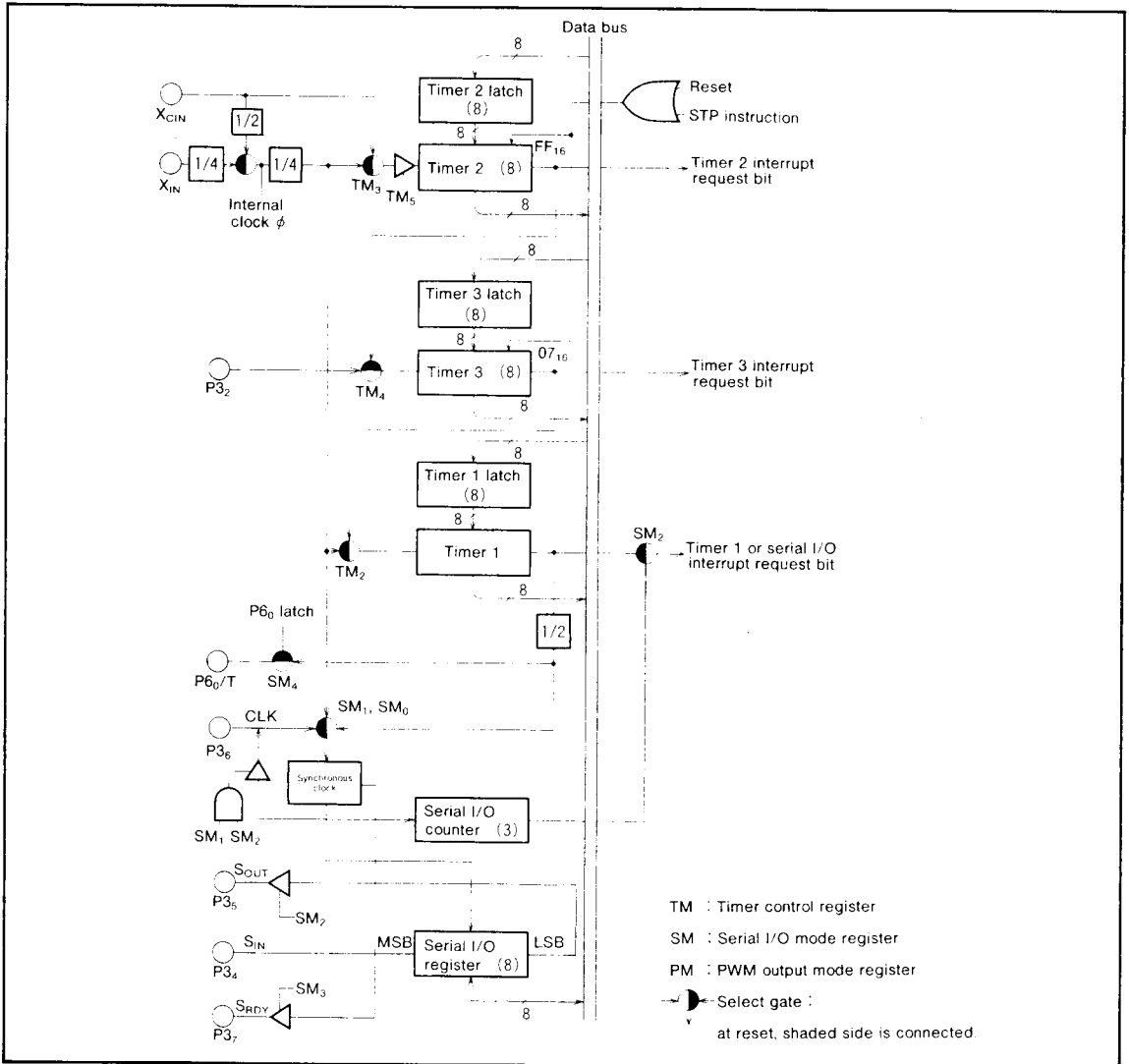

Fig. 5 Block diagram of timer 1 through 3

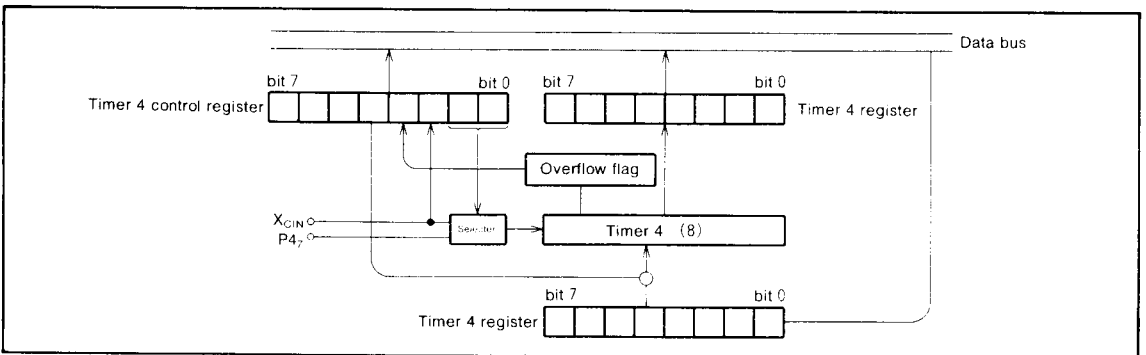

Fig. 6 Block diagram of timer 4

**SINGLE-CHIP 8-BIT CMOS MICROCOMPUTER for VOLTAGE SYNTHESIZER  
with ON-SCREEN DISPLAY CONTROLLER**

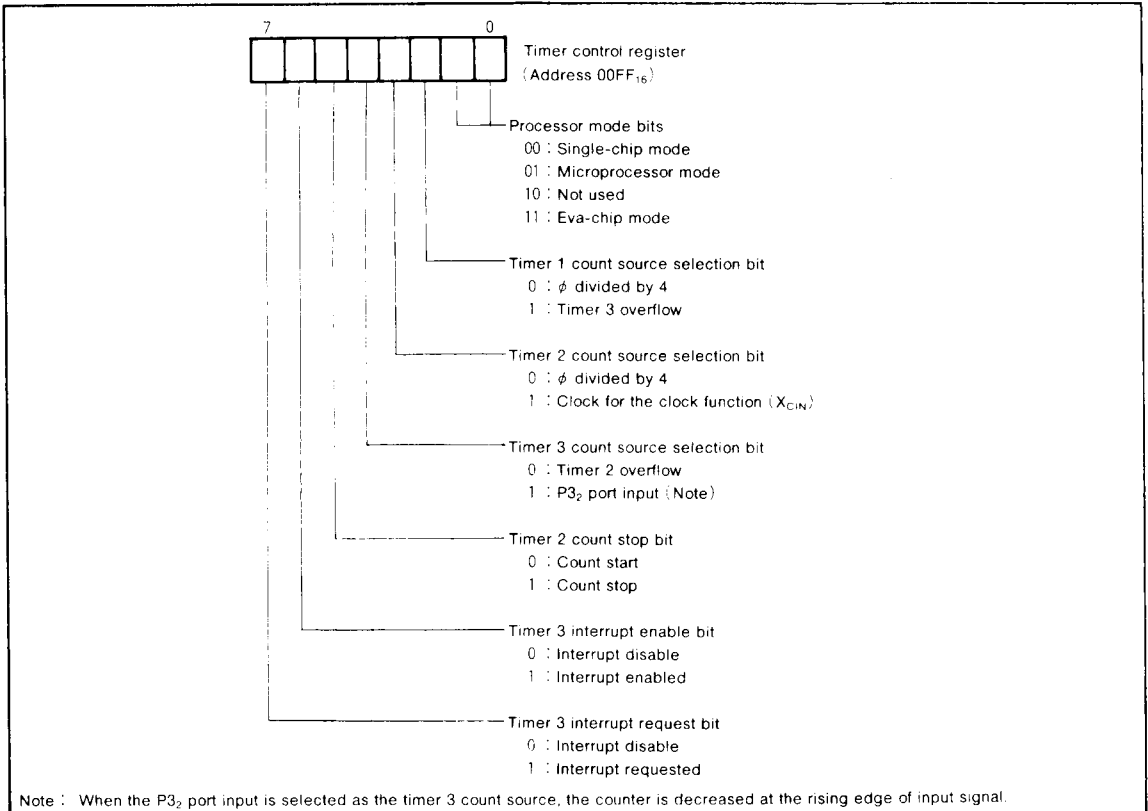

Fig. 7 Structure of timer control register

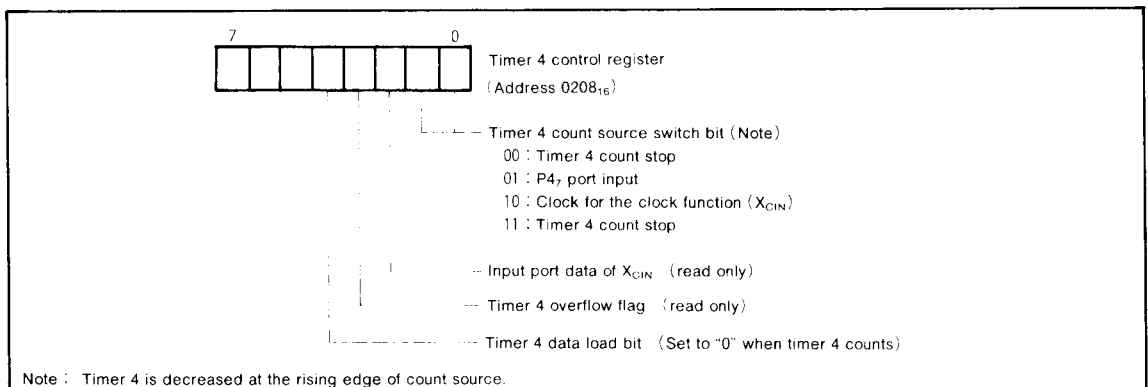

Fig. 8 Structure of timer 4 control register

**SINGLE-CHIP 8-BIT CMOS MICROCOMPUTER for VOLTAGE SYNTHESIZER  
with ON-SCREEN DISPLAY CONTROLLER**

**SERIAL I/O**

The block diagram of serial I/O is shown in Figure 9. In the serial I/O mode the receive ready signal ( $\overline{S_{RDY}}$ ), synchronous input/output clock (CLK), and the serial I/O ( $S_{OUT}$ ,  $S_{IN}$ ), pins are used as P3<sub>7</sub>, P3<sub>6</sub>, P3<sub>5</sub>, and P3<sub>4</sub>, respectively. The serial I/O mode register (address 00F6<sub>16</sub>) is an 8-bit register. Bit 0 and 1 of this register is used to select a syn-

chronous clock source. When these bits are [00] or [01], an external clock from P3<sub>6</sub> is selected. When these bits are [10], the overflow signal divided by two from timer 1 becomes the synchronous clock. Therefore, changing the timer period will change the transfer speed. When the bits are [11], the internal clock  $\phi$  divided by 4 becomes the clock.

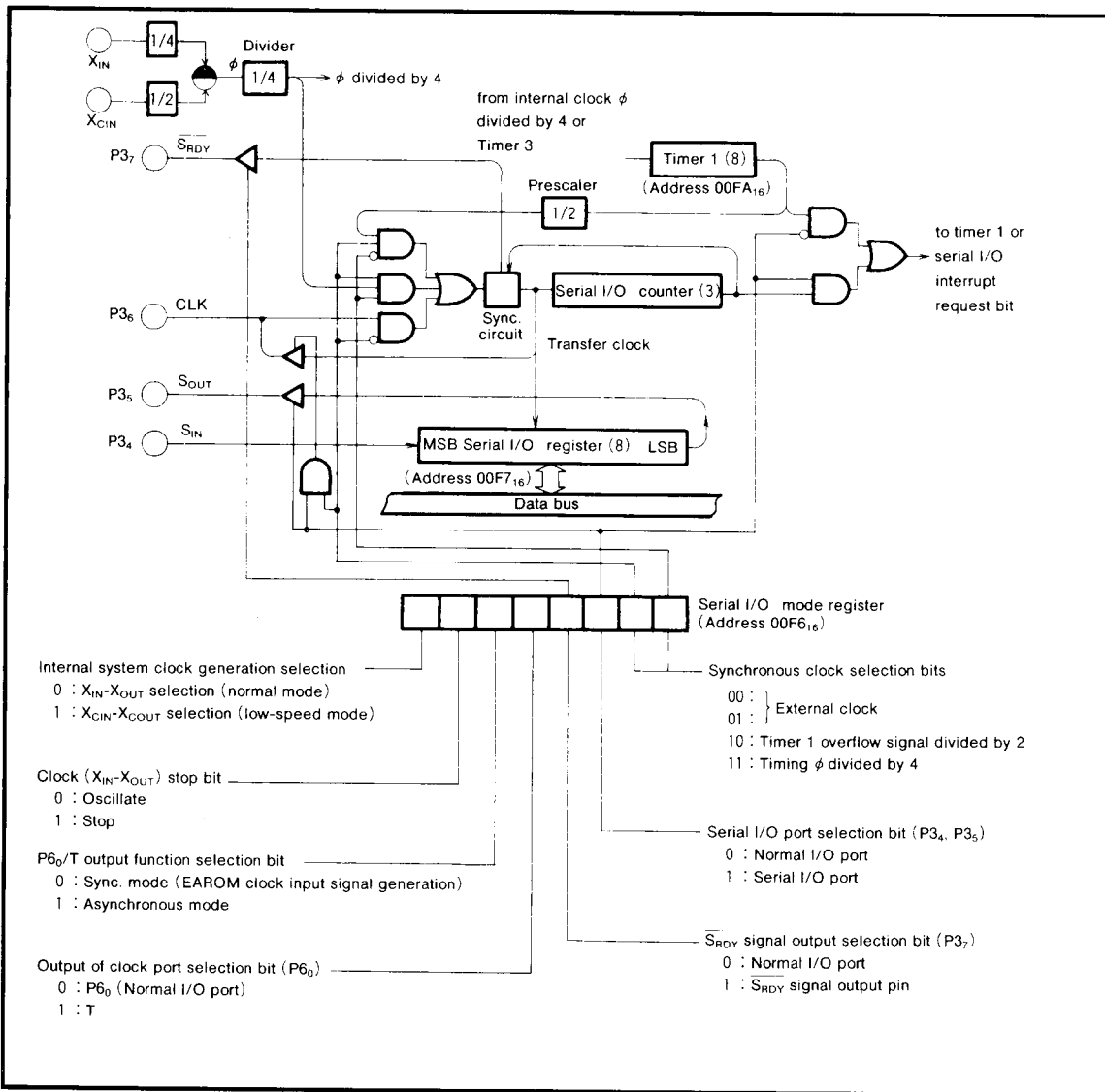

Fig. 9 Block diagram of serial I/O

**SINGLE-CHIP 8-BIT CMOS MICROCOMPUTER for VOLTAGE SYNTHESIZER  
with ON-SCREEN DISPLAY CONTROLLER**

Bits 2 and 3 decide whether parts of P3 will be used as a serial I/O or not. When bit 2 is "1", P3<sub>6</sub> becomes an I/O pin of the synchronous clock. When an internal synchronous clock is selected, the clock is output from P3<sub>6</sub>. If the external synchronous clock is selected, the clock is input to P3<sub>6</sub>. And P3<sub>5</sub> will be a serial output, and P3<sub>4</sub> will be a serial input. To use P3<sub>4</sub> as a serial input, set the directional register bit which corresponds to P3<sub>4</sub>, to "0". For more information on the directional register, refer to the I/O pin section. To use the serial I/O, bit 2 needs to be set to "1", if it is "0" P3<sub>6</sub> will function as a normal I/O. Interrupts will be generated from the serial I/O counter instead of timer 1. Bit 3 determines if P3<sub>7</sub> is used as an output pin for the receive data ready signal (bit 3="1", S<sub>RDY</sub>) or used as a normal I/O pin (bit 3="0").

The function of serial I/O differs depending on the clock source; external clock or internal clock.

**Internal Clock-** The S<sub>RDY</sub> signal becomes "H" during transmission or while dummy data is stored in the serial I/O register. After the falling edge of write signal, the S<sub>RDY</sub> signal

becomes low signaling that the M37103M4-XXXSP is ready to receive the external serial data. The S<sub>RDY</sub> signal goes "H" at the next falling edge of the transfer clock. The serial I/O counter is set to 7 when data is stored in the serial I/O register. At each falling edge of the transfer clock, serial data is output to P3<sub>5</sub>. During the rising edge of this clock, data can be input from P3<sub>4</sub> and the data in the serial I/O register will be shifted 1 bit. Data is output starting with the LSB. After the transfer clock has counted 8 times, the serial I/O register will be empty and the transfer clock will remain at a high level. At this time the interrupt request bit will be set.

**External Clock-** If an external clock is used, the interrupt request bit will be set after the transfer clock has counted 8 times but the transfer clock will not stop. Due to this reason, the external clock must be controlled from the outside. The external clock should not exceed 250kHz at a duty cycle of 50%.

Timing diagrams are shown in Figure 10, and connection between two M37103M4-XXXSP's are shown in Figure 11.

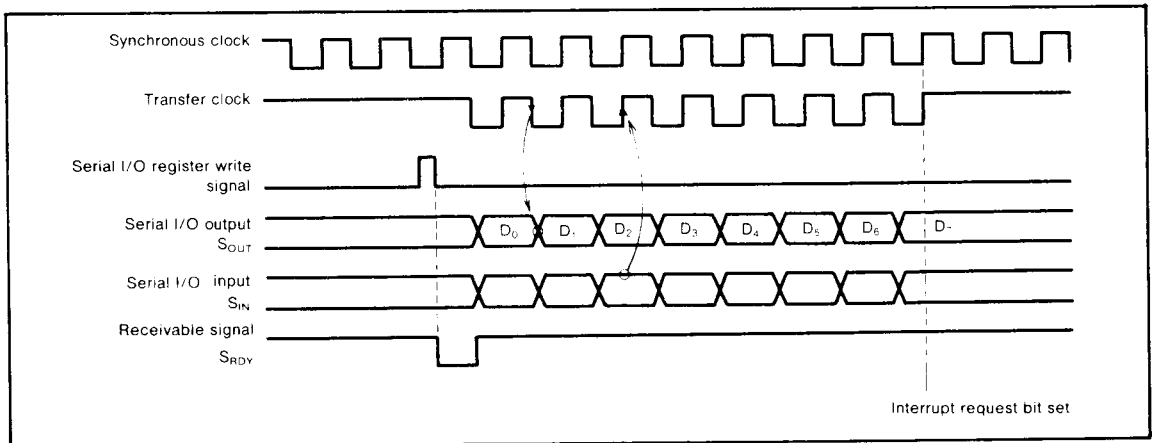

Fig. 10 Serial I/O timing

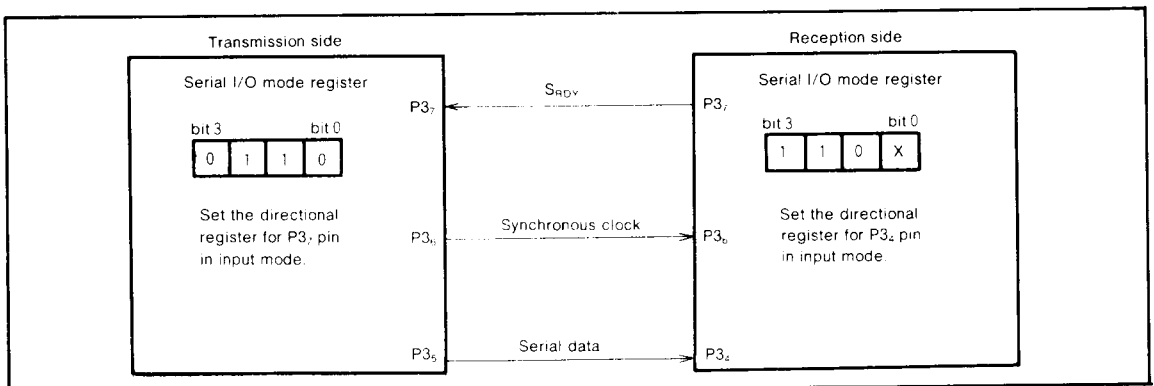

Fig. 11 Example for serial I/O connection

**SINGLE-CHIP 8-BIT CMOS MICROCOMPUTER for VOLTAGE SYNTHESIZER  
with ON-SCREEN DISPLAY CONTROLLER**

**PWM OUTPUT CIRCUIT**

(1) Introduction

The M37103M4-XXXSP is equipped with one 14-bit PWM, four 8-bit PWMs and six 6-bit PWMs. The 14-bit resolution gives PWM1 the minimum resolution bit width of 500ns (for  $X_{IN} = 4\text{MHz}$ ) and a repeat period of 8192  $\mu\text{s}$ . PWM7, PWM8, PWM9, PWM10 have a 8-bit resolution with minimum resolution bit width of 16 $\mu\text{s}$  and repeat period of 4096 $\mu\text{s}$ . PWM0, PWM2, PWM3, PWM4, PWM5, PWM6 have a 6-bit resolution with minimum resolution bit width of 16 $\mu\text{s}$  and repeat period of 1024 $\mu\text{s}$ . Accuracy and operation range is certified of PWM are  $V_{CC} = 4.5$  to 5.5V regardless of input frequency. Block diagram of the PWM is shown in Figures 12 and 13.

The PWM timing generator section applies individual control signals to PWM 0-10, using clock input  $X_{IN}$  divided by 2 or  $X_{CIN}$  divided by 2 as a reference signal.

(2) Data setting

The output pins PWM0-PWM5 are in common with pins  $P6_0$ - $P6_5$  of port P6 and PWM6-PWM10 are in common with pins  $P5_1$ - $P5_7$  of port P5 (i.e. for PWM output, PWM output selection bits and the P5, P6 directional register  $D5_1$ - $D5_7$ ,  $D6_0$ - $D6_5$  should be set). When PWM1 is used for output, first set the higher 8-bit of the PWM1-H register (address 00F0<sub>16</sub>), then the lower 6-bit of the PWM1-L register (address 00F1<sub>16</sub>). When either PWM0 and PWM2-10 is used for output, set the 8-bit in the PWM0 and PWM2-10 register, respectively. Note that the higher 2 bits of these 8-bit registers are ignored when used 6-bit register.

(3) Transferring data from registers to latches

The data written to the 6-bit or 8-bit PWM register is transferred to the PWM latch in each 6-bit PWM cycle period. For 14-bit PWM, the data is transferred in the next upper 8-bit period after the write. The signals output to the PWM pins correspond to the contents of these latches. When data at addresses 00F0<sub>16</sub> to 00F4<sub>16</sub>, 00F8<sub>16</sub>, 0200<sub>16</sub> to 0205<sub>16</sub> is read, data in these latches has already been read allowing the data output by the PWM to be confirmed. When the 6-bit latch is being read, the upper 2 bits of the register becomes undefined. However, bit 7 of the PWM1-L register indicated the completion of the data transfer from the PWM1 register to the PWM1 latch. if bit 7 is "0", the transfer has been completed, if bit 7 is "1", the transfer has not yet begun.

(4) Operation of the 6-bit PWMs

The timing diagram of the two 6-bit PWMs (PWM0 and PWM2-6) is shown in Figure 14. One period (T) is composed of 64 ( $2^6$ ) segments.

There are six different pulse types configured from bits 0 to 5 representing the significance of each bit. These are output within one period in the circuit internal section. Refer to Figure 14 (a).

Six different pulses can be output from the PWM. These can be selected by bits 0 through 5. Depending on the content of the 6-bit PWM latch, pulses from 5 to 0 is selected. The PWM output is the difference of the sum of each of these pulses. Several examples are shown in Figure 14 (b). Changes in the contents of the PWM latch allows the selection of 64 lengths of high-level area outputs varying from 0/64 to 63/64. An length of entirely high-level output cannot be output. i.e. 64/64.

(5) 8-bit PWM operation

8-bit PWM operation is the same as 6-bit PWM operation except that one period (T) is composed of 256 ( $2^8$ ) segments.

(6) 14-bit PWM operation

The timing diagram of the 14-bit PWM1 is shown in Figure 15. The 14-bit PWM divides the data within the PWM latch into the lower 6 bits and higher 8 bits.

A high-level area within a length N times  $\tau$  is output every short area of  $t = 256 \tau = 128 \mu\text{s}$  as determined by data N of the higher 8 bits. (Refer to PWM output 2 in the lower part of Figure 15.)

Thus, the time for the high-level area is equal to the time set by the lower 8 bits or that plus  $\tau$ . As a result, the short-area period t ( $= 128 \mu\text{s}$ , approx. 7.8kHz) becomes an approximately repetitive period.

(7) Output after reset

At reset the output of port P5, P6 is in the high impedance state and the contents of the PWM register and latch are undefined. Note that after setting the PWM register, its data is transferred to the latch.

**Table 2. Relation between the 6 lower-order bits of data and the space set by the ADD bit**

6 lower-order bits of data	Area longer by $\tau$ than that of other $t_m$ ( $m = 0$ to 63)
0 0 0 0 0 0 <sup>LSB</sup>	Nothing
0 0 0 0 0 1	$m = 32$
0 0 0 0 1 0	$m = 16, 48$
0 0 0 1 0 0	$m = 8, 24, 40, 56$
0 0 1 0 0 0	$m = 4, 12, 20, 28, 36, 44, 52, 60$
0 1 0 0 0 0	$m = 2, 6, 10, 14, 18, 22, 26, 30, 34, 38, 42, 46, 50, 54, 58, 62$
1 0 0 0 0 0	$m = 1, 3, 5, 7, \dots, 57, 59, 61, 63$

**SINGLE-CHIP 8-BIT CMOS MICROCOMPUTER for VOLTAGE SYNTHESIZER  
 with ON-SCREEN DISPLAY CONTROLLER**

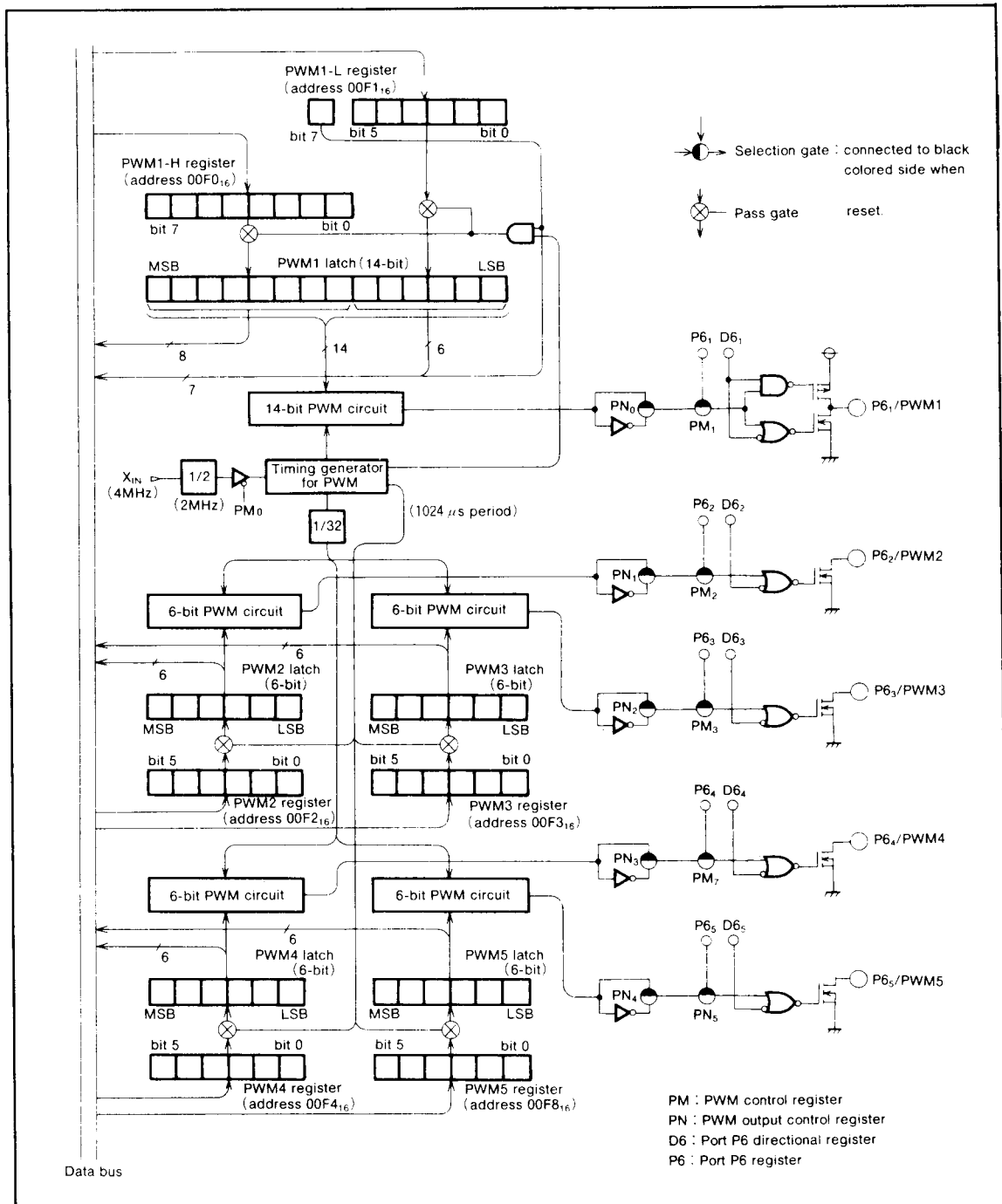

Fig. 12 Block diagram of the PWM circuit (1)

**SINGLE-CHIP 8-BIT CMOS MICROCOMPUTER for VOLTAGE SYNTHESIZER  
 with ON-SCREEN DISPLAY CONTROLLER**

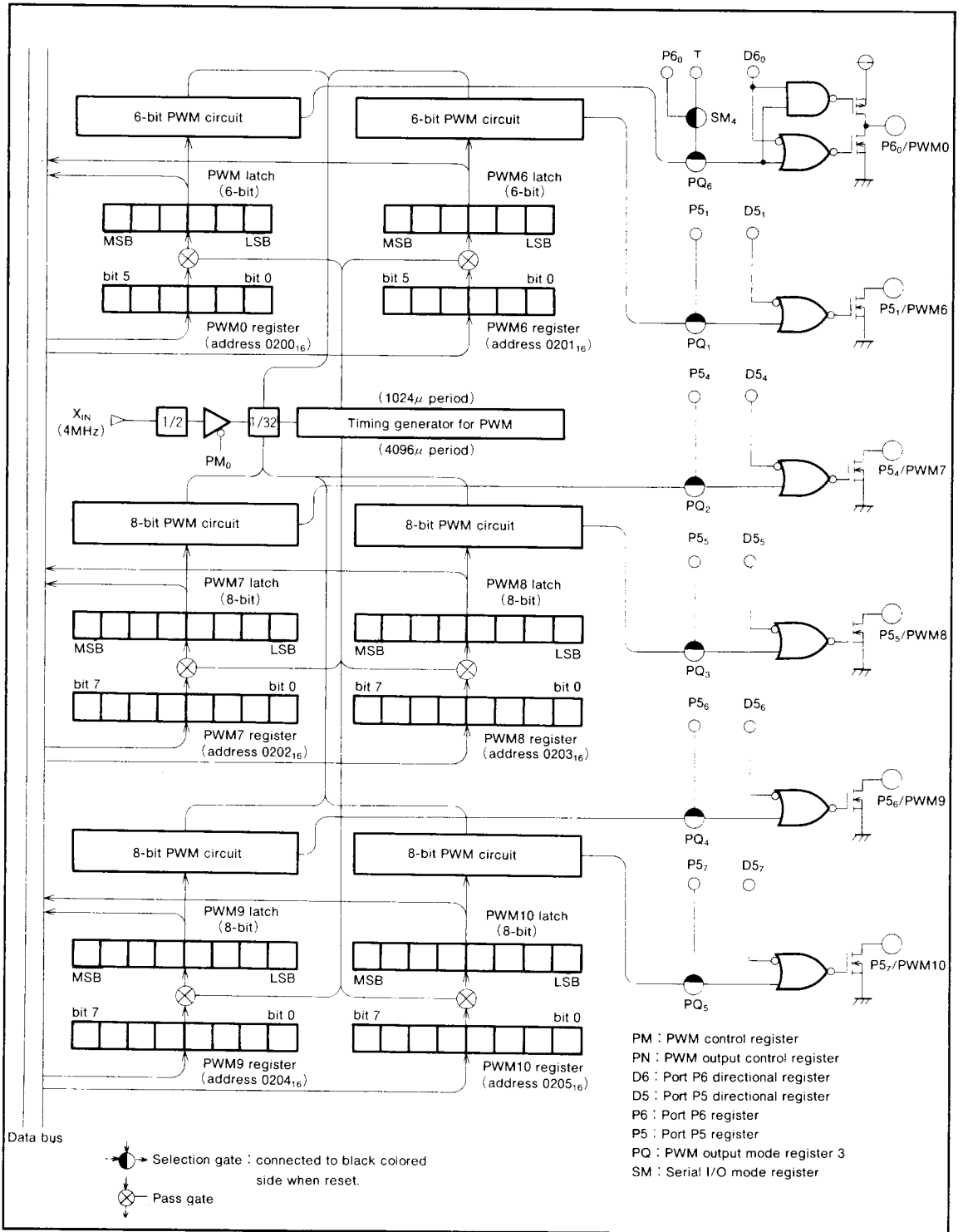

Fig. 13 Block diagram of the PWM circuit (2)



**SINGLE-CHIP 8-BIT CMOS MICROCOMPUTER for VOLTAGE SYNTHESIZER  
with ON-SCREEN DISPLAY CONTROLLER**

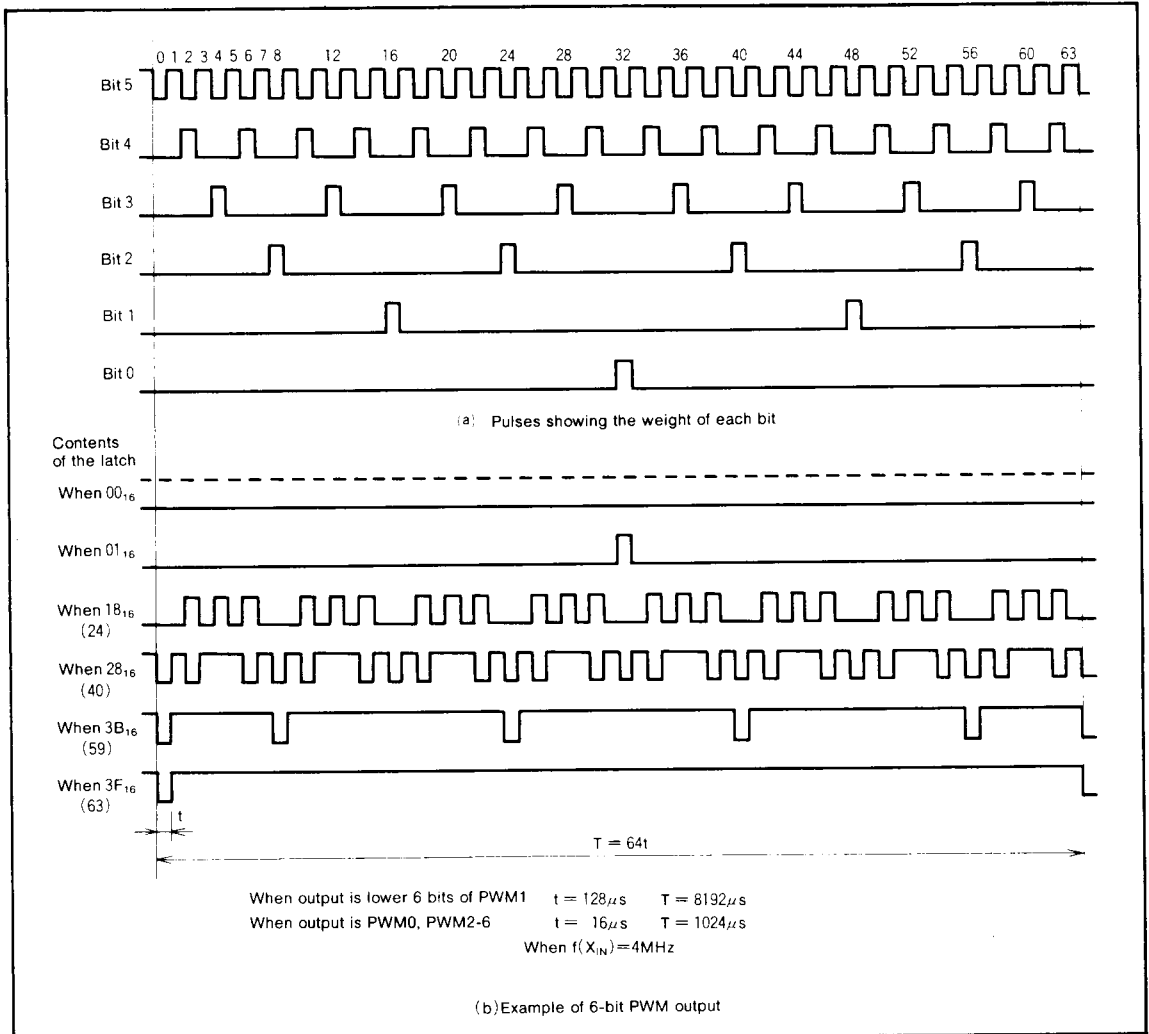

Fig. 14 6-bit PWM timing diagram

**SINGLE-CHIP 8-BIT CMOS MICROCOMPUTER for VOLTAGE SYNTHESIZER  
 with ON-SCREEN DISPLAY CONTROLLER**

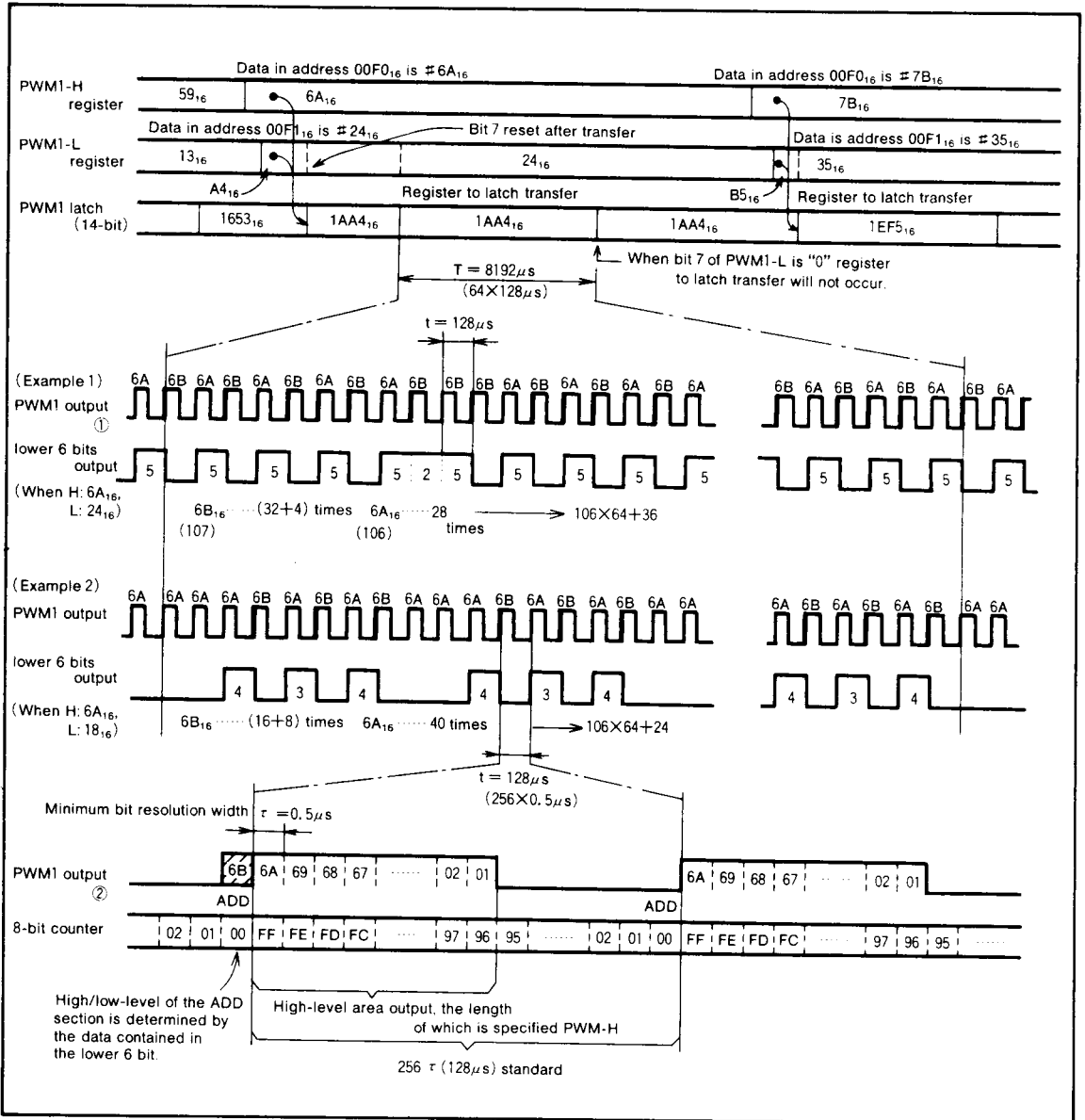

Fig. 15 14-bit PWM timing diagram

**SINGLE-CHIP 8-BIT CMOS MICROCOMPUTER for VOLTAGE SYNTHESIZER  
with ON-SCREEN DISPLAY CONTROLLER**

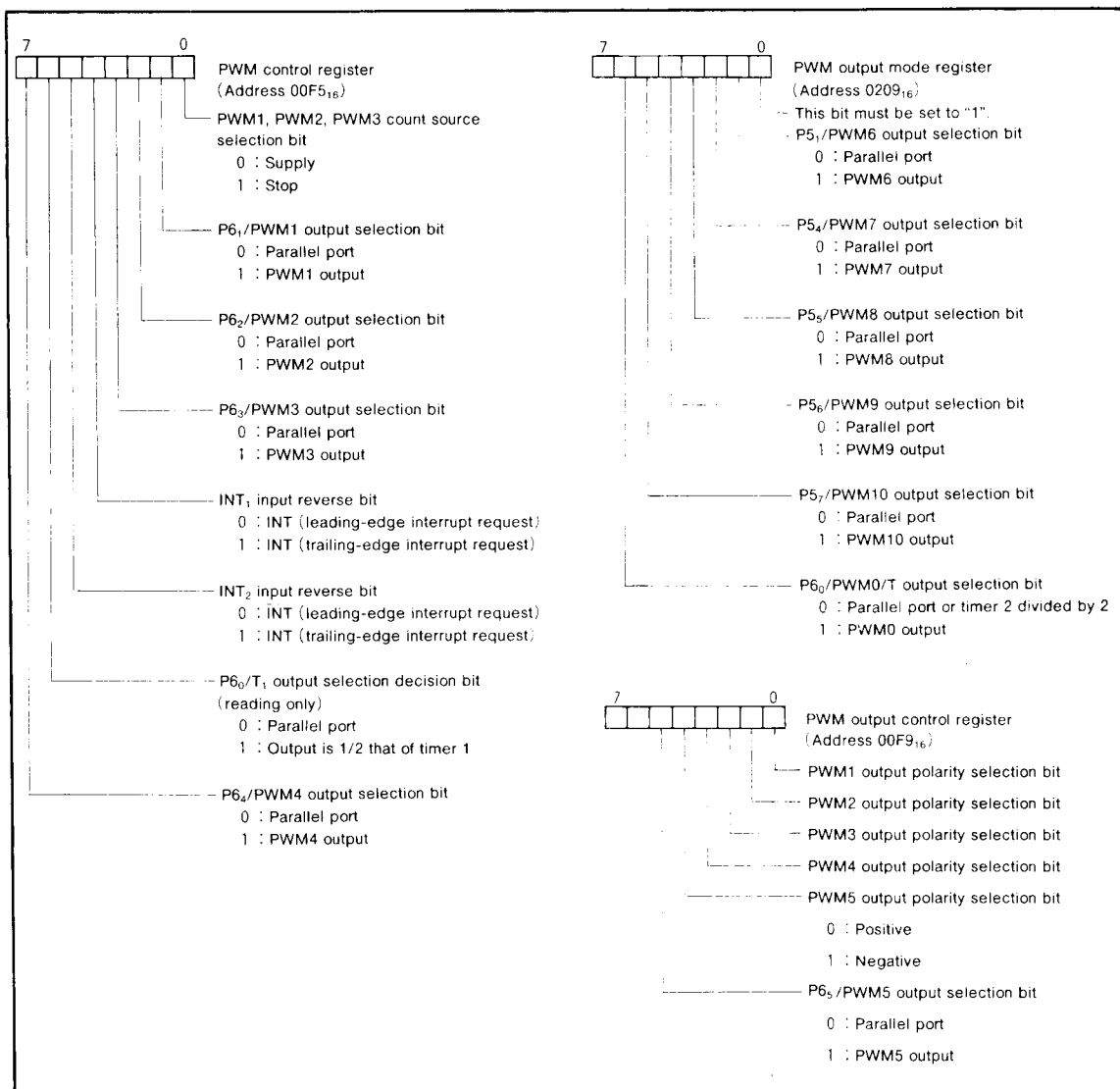

Fig. 16 Structure of registers related to PWM

**SINGLE-CHIP 8-BIT CMOS MICROCOMPUTER for VOLTAGE SYNTHESIZER  
with ON-SCREEN DISPLAY CONTROLLER**

**PORT P6<sub>0</sub> / TIMER 1 OUTPUT**

Bit 0 of port P6<sub>0</sub> outputs 1/2 the frequency of timer 1 when bit 6 of the PWM output mode register is set to "0" and bit 4 (SM<sub>4</sub>) of the serial I/O mode register (address 00F6<sub>16</sub>) is set to "1". The output switching can be accomplished with either of two procedures, synchronous mode or asynchronous mode, depending on the setting of bit 5 (SM<sub>5</sub>) of the serial I/O mode register.

When SM<sub>5</sub> is set to "0" the synchronous mode is set. In such a case, after SM<sub>4</sub> has been changed, synchronization is set to the 1/2 frequency of timer 1 and switching between the port latch and timer takes place. It is possible to ascertain whether switching actually occurred by reading

the value of bit 6 of the PWM control register.

From the time that the contents of SM<sub>4</sub> was changed to the point where switching completes, the contents of neither SM<sub>4</sub> nor P6<sub>0</sub> may be changed. Use of the synchronous mode prevents the generation of a pulse shorter than the timer output during switching. Figure 17 (a) gives an example of timing in the synchronous mode. Use of the synchronous mode allows generation of an EAROM clock input signal through the use of a simple program.

When SM<sub>5</sub> is set to "1", the asynchronous mode is set. In this case, the output switching occurs directly after SM<sub>4</sub> has been changed. Figure 17 (b) gives an example of timing in the asynchronous mode.

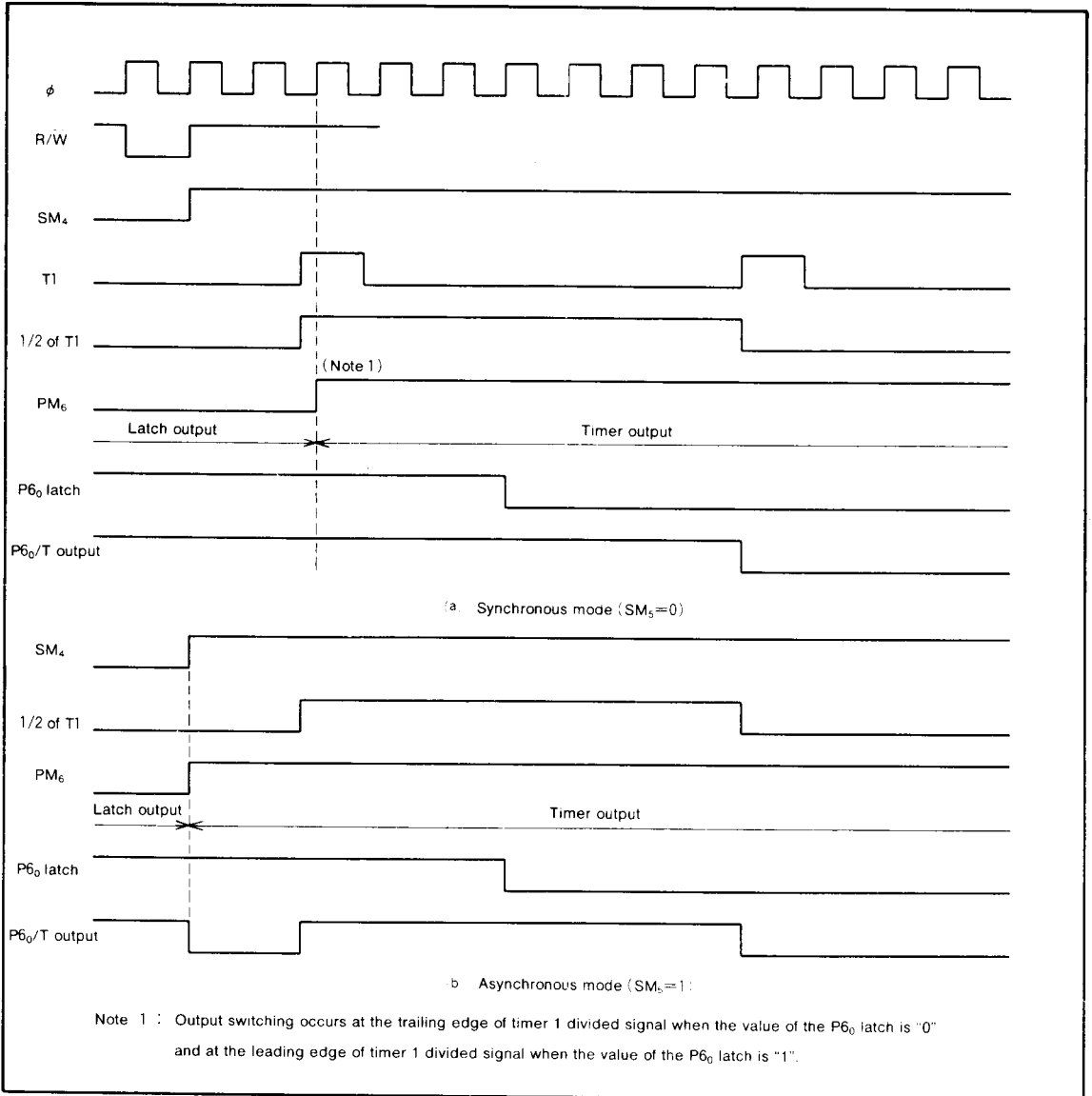

**Fig. 17 P6<sub>0</sub>/T switching timing diagram**

**SINGLE-CHIP 8-BIT CMOS MICROCOMPUTER for VOLTAGE SYNTHESIZER  
with ON-SCREEN DISPLAY CONTROLLER**

**COMPARATOR CIRCUIT**

The comparator circuit is shown in Figure 18. The comparator circuit consists of the switch tree, ladder resistor, comparator, comparator control circuit, A-D control register (address 00E7<sub>16</sub>), and analog signal input pin (P3<sub>3</sub>/A-D). The analog input pin is common with the digital input/output terminal to the data bus.

The 5-bit A-D control register can generate 1/16V<sub>CC</sub>-step internal analog voltage, based on the settings of bits 0 to 3. Table 3 gives the relation between the descriptions of A-D control register bits 0 to 3 and the generated internal analog voltage. The comparator result of the analog input voltage and the internal analog voltage is stored in the A-D control register, bit 4.

The data is compared by setting the directional register corresponding to port P3<sub>3</sub> to "0" (port P3<sub>3</sub> enters the input mode), to allow port P3<sub>3</sub>/A-D to be used as the analog input pin. The digital value corresponding to the internal analog voltage to be compared is then written in the A-D control register (address 00E7<sub>16</sub>), bits 0 to 3. The voltage comparison starts as soon as the writing is completed. 4-cycle (required for comparing) later, the result of comparison is stored in the A-D control register, bit 4. Bit 4 is "1" when analog input voltage > internal analog voltage and "0" when analog input voltage < internal analog voltage.

When voltage is compared to by setting bits 0 to 3 of the comparator register "0", bit 4 of the A-D control register becomes "1" regardless of the analog input voltage.

Table 3. Relationship between the contents of A-D control register and internal voltage

A-D control register				Internal analog voltage
bit 3	bit 2	bit 1	bit 0	
0	0	0	1	1/16V <sub>CC</sub> -1/32V <sub>CC</sub>
0	0	1	0	2/16V <sub>CC</sub> -1/32V <sub>CC</sub>
0	0	1	1	3/16V <sub>CC</sub> -1/32V <sub>CC</sub>
0	1	0	0	4/16V <sub>CC</sub> -1/32V <sub>CC</sub>
0	1	0	1	5/16V <sub>CC</sub> -1/32V <sub>CC</sub>
0	1	1	0	6/16V <sub>CC</sub> -1/32V <sub>CC</sub>
0	1	1	1	7/16V <sub>CC</sub> -1/32V <sub>CC</sub>
1	0	0	0	8/16V <sub>CC</sub> -1/32V <sub>CC</sub>
1	0	0	1	9/16V <sub>CC</sub> -1/32V <sub>CC</sub>
1	0	1	0	10/16V <sub>CC</sub> -1/32V <sub>CC</sub>
1	0	1	1	11/16V <sub>CC</sub> -1/32V <sub>CC</sub>
1	1	0	0	12/16V <sub>CC</sub> -1/32V <sub>CC</sub>
1	1	0	1	13/16V <sub>CC</sub> -1/32V <sub>CC</sub>
1	1	1	0	14/16V <sub>CC</sub> -1/32V <sub>CC</sub>
1	1	1	1	15/16V <sub>CC</sub> -1/32V <sub>CC</sub>

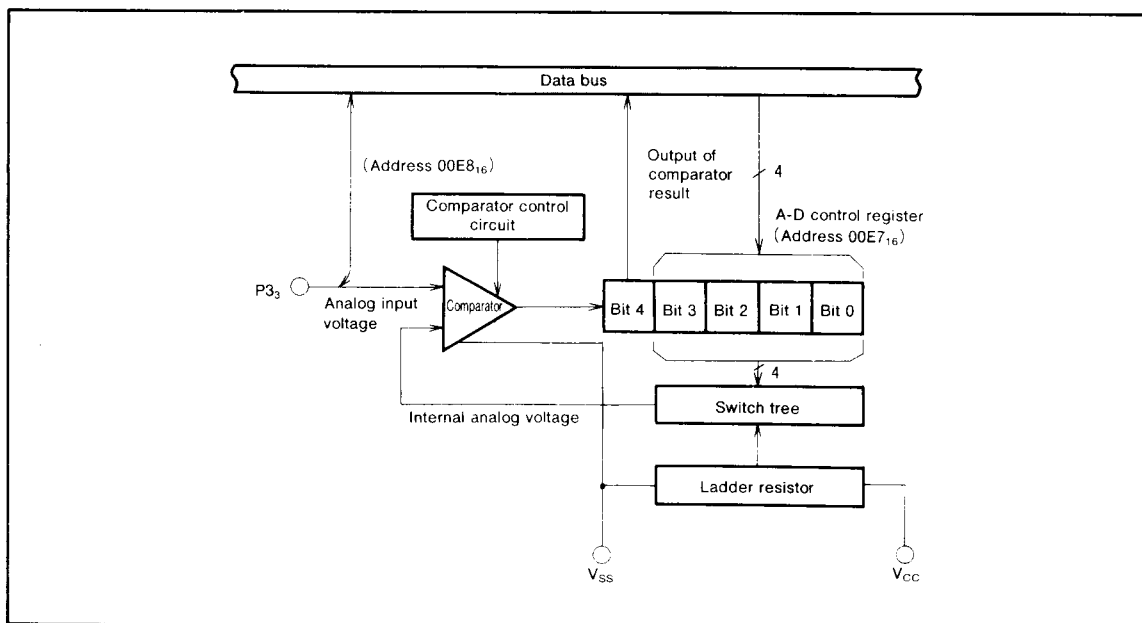

Fig. 18 Comparator Circuit

**SINGLE-CHIP 8-BIT CMOS MICROCOMPUTER for VOLTAGE SYNTHESIZER  
with ON-SCREEN DISPLAY CONTROLLER**

**CRT DISPLAY FUNCTIONS**

**(1) Outline of CRT Display functions**

Table 4 outlines the CRT display functions. The M37103M4-XXXSP incorporates a 21 columns  $\times$  3 lines CRT display control circuit. CRT display is controlled by the CRT display control register. Up to 96 kinds of characters can be displayed, and colors can be specified for each character. Four colors can be displayed on one screen. A combination of up to 15 colors can be obtained by using each output signal (R, G, B, and I).

Characters are displayed in a 12  $\times$  16 dot configuration to obtain smooth character patterns. (See Figure 19)

The following shows the procedure how to display characters on the CRT screen.

- ① Set the character to be displayed in display RAM.
- ② Set the display color by using the color register.
- ③ Specify the color register in which the display color is set by using the display RAM.
- ④ Specify the vertical position and character size by using the vertical position register.
- ⑤ Specify the horizontal position by using the horizontal position register.
- ⑥ Write the display enable bit to the designated block display flag of the CRT control register. When this is done, the CRT starts operation according to the input of the  $V_{SYNC}$  signal.

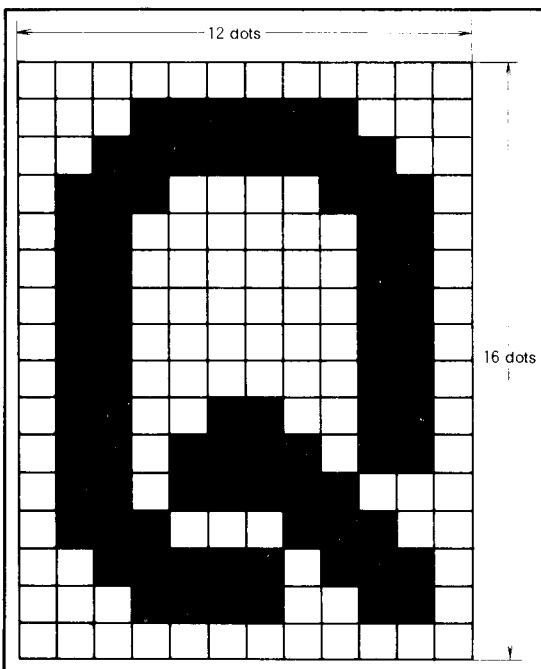

Fig. 19 CRT display character configuration

The CRT display circuit has an extended display mode. This mode allows multiple lines (more than 3 lines) to be displayed on the screen by interrupting the display each time one line is displayed and rewriting data in the block for which display is terminated by software.

Figure 21 shows a block diagram of the CRT display control circuit. Figure 20 shows the structure of the CRT display control register.

Table 4. Outline of CRT display functions

Parameter	Functions	
Number of display character	21 characters $\times$ 3 lines	
Character configuration	12 $\times$ 16 dots (See Figure 19)	
Kinds of character	96	
Character size	4 size selectable	
Color	Kinds of color	15 (max.)
	Coloring unit	a character
Display expansion	Possible (multiple lines)	

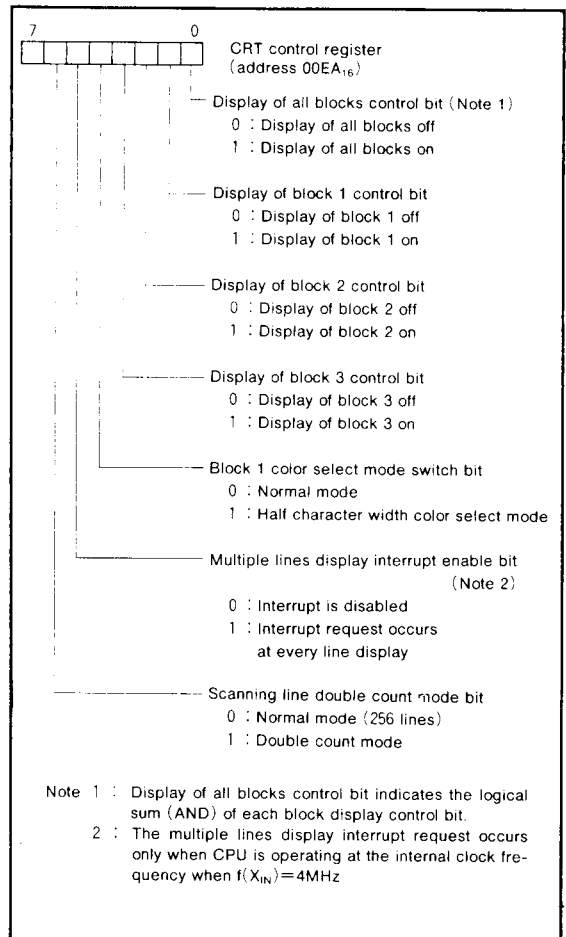

Fig. 20 Structure of CRT control register

**SINGLE-CHIP 8-BIT CMOS MICROCOMPUTER for VOLTAGE SYNTHESIZER  
with ON-SCREEN DISPLAY CONTROLLER**

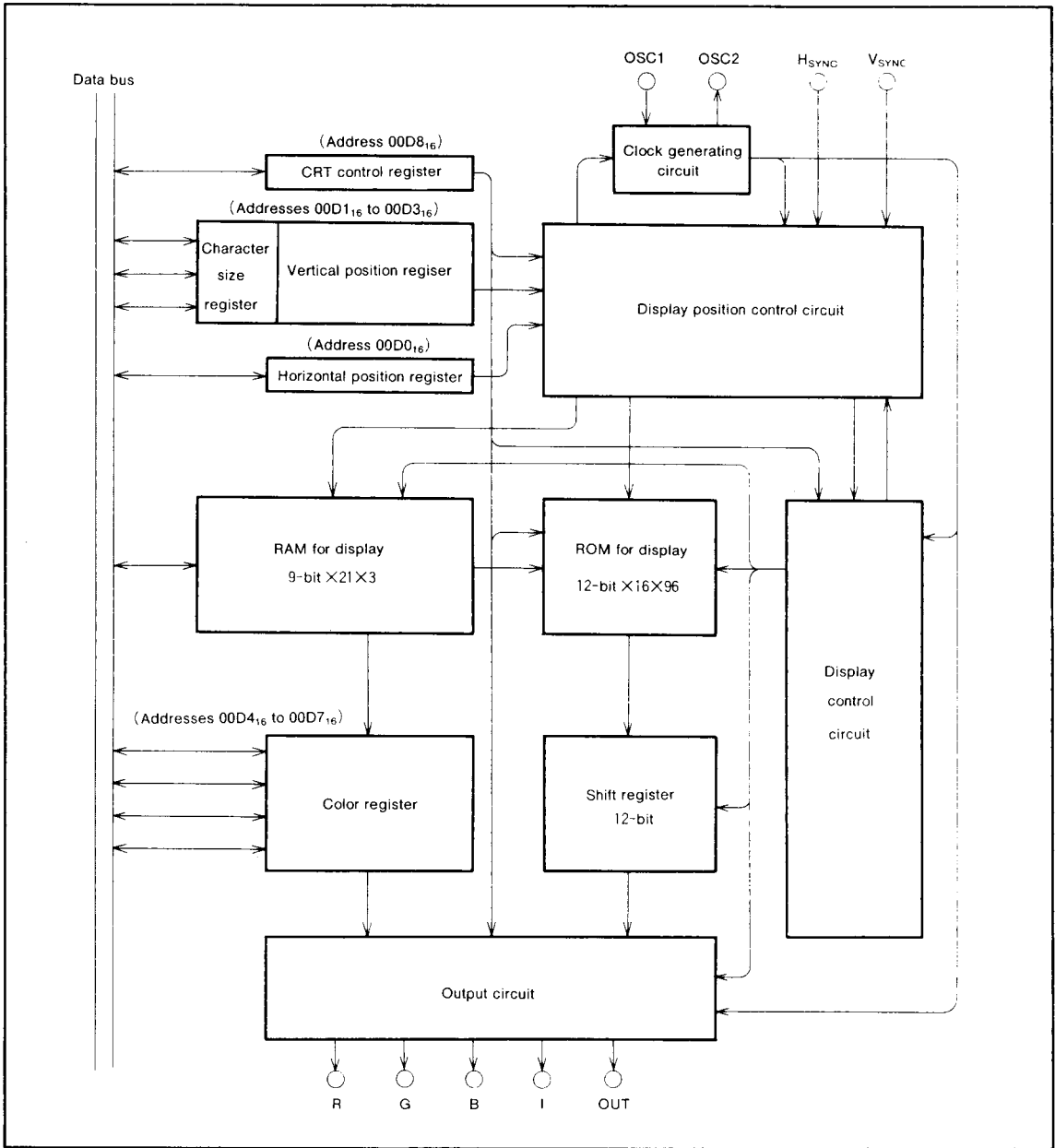

Fig. 21 Block diagram of CRT display control circuit

**SINGLE-CHIP 8-BIT CMOS MICROCOMPUTER for VOLTAGE SYNTHESIZER  
with ON-SCREEN DISPLAY CONTROLLER**

**(2) Display Position**

The display positions of characters are specified in units called a "block." There are three blocks, block 1 to block 3. Up to 21 characters can be displayed in one block. (See (4) Display Memory.)

The display position of each block in both horizontal and vertical directions can be set by software.

The horizontal direction is common to all blocks, and is selected from 64-step display positions in units of 4Tc (Tc=oscillation cycle for display).

The display position in the vertical direction is selected from 64-step display positions for each block in units of four scanning lines.

If the display start position of a block overlaps with some other block ((b) in Figure 24), a block of the smaller block No. (1 to 3) is displayed.

If when one block is displaying, some other block is displayed at the same display position ((c) in Figure 24), the former block is overridden and the latter is displayed.

The vertical position can be specified from 64-step positions (four scanning lines per step) for each block by setting values 00<sub>16</sub> to 3F<sub>16</sub> to bits 0 to 5 in the vertical position register (addresses 00D1<sub>16</sub> to 00D3<sub>16</sub>). Figure 22 shows the structure of the vertical position register.

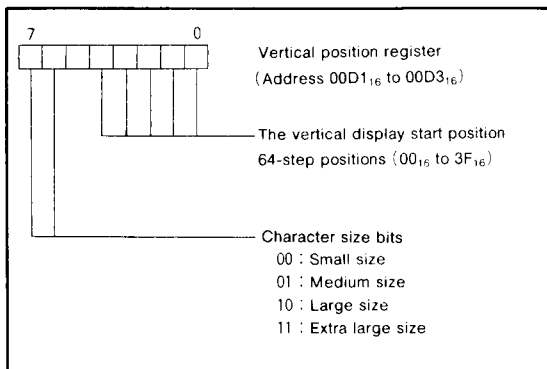

Fig. 22 Structure of vertical position registers

The horizontal direction is common to all blocks, and can be specified from 64-step display positions (4Tc per step (Tc=oscillation cycle for display) by setting values 00<sub>16</sub> to 3F<sub>16</sub> to bits 0 to 5 in the horizontal position register (address 00D0<sub>16</sub>).

Figure 23 shows the structure of the horizontal position register.

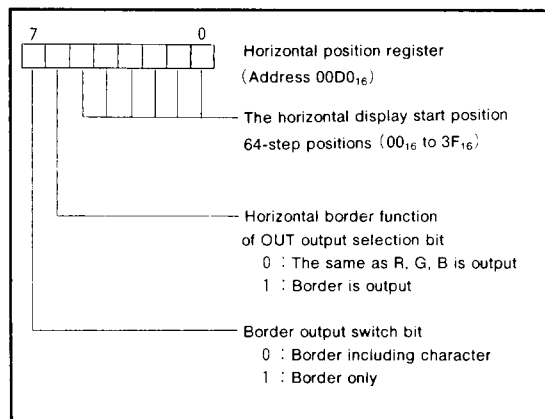

Fig. 23 Structure of horizontal position register



**SINGLE-CHIP 8-BIT CMOS MICROCOMPUTER for VOLTAGE SYNTHESIZER  
 with ON-SCREEN DISPLAY CONTROLLER**

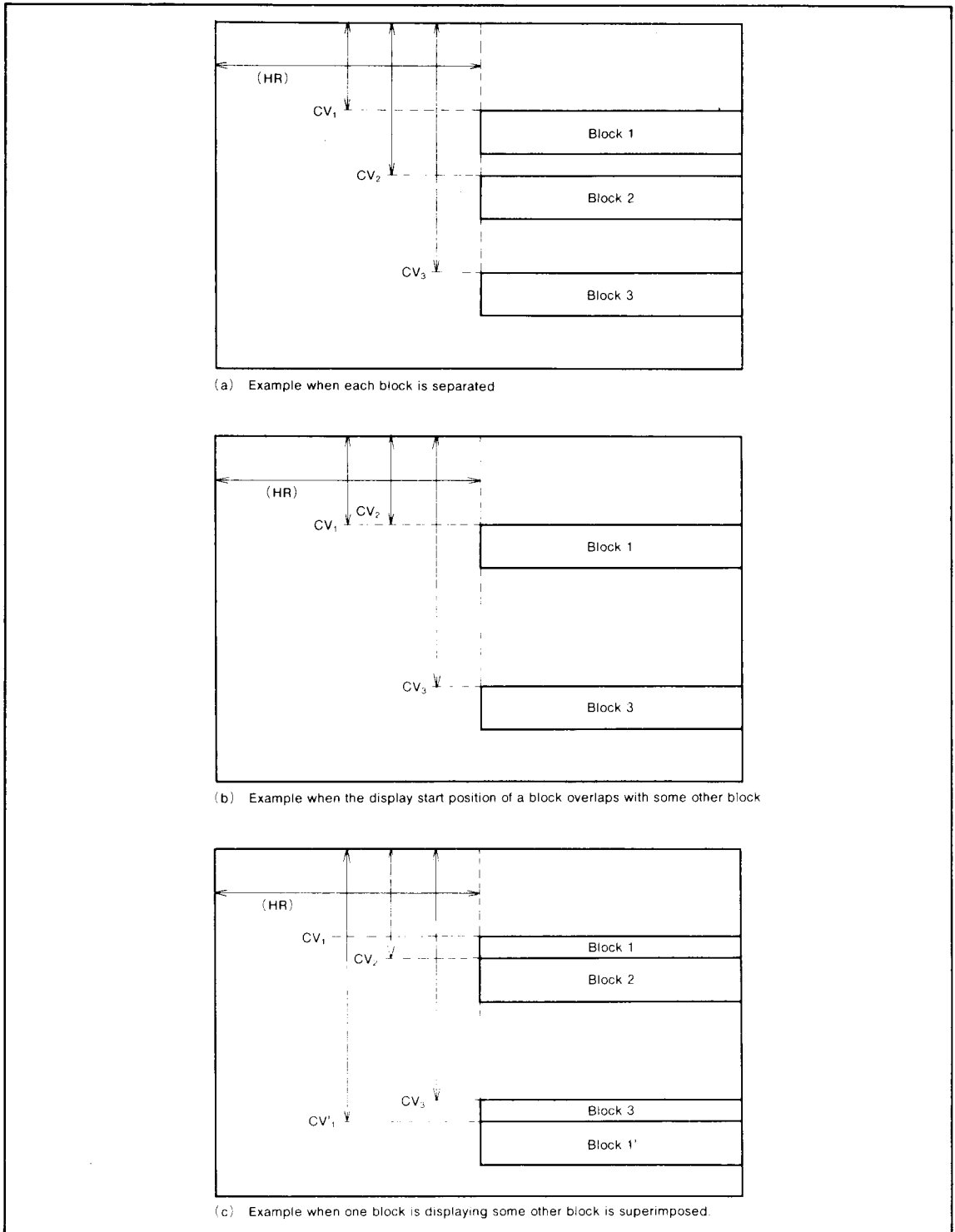

Fig. 24 Display position

**SINGLE-CHIP 8-BIT CMOS MICROCOMPUTER for VOLTAGE SYNTHESIZER  
with ON-SCREEN DISPLAY CONTROLLER**

**(3) Character Size**

The size of characters to be displayed can be selected from four sizes for each block. Use the bit 6 and 7 of vertical position register to set a character size.

The character size can be selected from four sizes: small size, medium size, large size, and extra large size. Each character size is determined by the number of scanning lines in the height (vertical) direction and the cycle of display oscillation ( $=T_c$ ) in the width (horizontal) direction.

The small size consists of [one scanning line]  $\times$  [1  $T_c$ ]; the medium size consists of [two scanning lines]  $\times$  [2  $T_c$ ]; the large size consists of [three scanning lines]  $\times$  [3  $T_c$ ]; and the extra large size consists of [four scanning lines]  $\times$  [4  $T_c$ ]. Table 5 shows the relationship between the set values in the character size register and the character sizes.

**Table 5. The relationship between the set values of the character size bits and the character sizes.**

Set values of the character size bits		Character size	Width (horizontal) direction	Height (vertical) direction
Bit7	Bit6			
0	0	Small	1 $T_c$	1
0	1	Medium	2 $T_c$	2
1	0	Large	3 $T_c$	3
1	1	Extra large	4 $T_c$	4

Note : The display start position in the horizontal direction is not affected by the character size. In other words, the horizontal start position is common to all blocks even when the character size varies with each block. (See Figure 25)

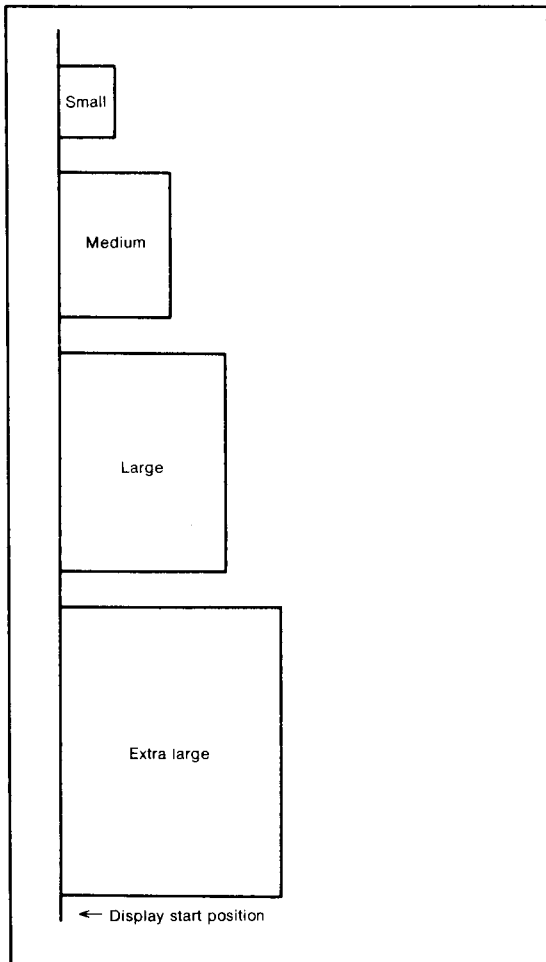

**Fig. 25 Display start position of each character size (horizontal direction)**

**SINGLE-CHIP 8-BIT CMOS MICROCOMPUTER for VOLTAGE SYNTHESIZER  
with ON-SCREEN DISPLAY CONTROLLER**

#### (4) RAM for display

RAM for display is allocated at addresses  $2000_{16}$  to  $20D4_{16}$ , and is divided into a display character code specifying part and display color specifying part for each block. Table 6 shows the contents of the CRT display RAM.

When a character is to be display at the first character (leftmost) position in block 1, for example, it is necessary to write the character code to the seven low-order bits (bits 0 to 6) in address  $2000_{16}$  and the color register No. to the two low-order bits (bits 0 and 1) in address  $2080_{16}$ . The color register No. to be written here is one of the four color registers in which the color to be displayed is set in advance. For details on color registers, refer to (5) Color Registers.

The structure of the CRT display RAM is shown in Figure 26.

Table 6. The contents of the CRT display RAM

Block	Display position (from left)	Character code specification	Color specification
Block 1	1 st Column	$2000_{16}$	$2080_{16}$
	2 nd Column	$2001_{16}$	$2081_{16}$
	3 rd Column	$2002_{16}$	$2082_{16}$
	⋮	⋮	⋮
	19th Column	$2012_{16}$	$2092_{16}$
	20th Column	$2013_{16}$	$2093_{16}$
	21th Column	$2014_{16}$	$2094_{16}$
Block 2	Not used	$2015_{16}$ to $201F_{16}$	$2095_{16}$ to $209F_{16}$
	1 st Column	$2020_{16}$	$20A0_{16}$
	2 nd Column	$2021_{16}$	$20A1_{16}$
	3 rd Column	$2022_{16}$	$20A2_{16}$
	⋮	⋮	⋮
	19th Column	$2032_{16}$	$20B2_{16}$
	20th Column	$2033_{16}$	$20B3_{16}$
	21th Column	$2034_{16}$	$20B4_{16}$
	Not used	$2035_{16}$ to $203F_{16}$	$20B5_{16}$ to $20BF_{16}$
	Block 3	1 st Column	$2040_{16}$
2 nd Column		$2041_{16}$	$20C1_{16}$
3 rd Column		$2042_{16}$	$20C2_{16}$
⋮		⋮	⋮
19th Column		$2052_{16}$	$20D2_{16}$
20th Column		$2053_{16}$	$20D3_{16}$
21th Column		$2054_{16}$	$20D4_{16}$
Not used		$2055_{16}$ to $207F_{16}$	

**SINGLE-CHIP 8-BIT CMOS MICROCOMPUTER for VOLTAGE SYNTHESIZER  
with ON-SCREEN DISPLAY CONTROLLER**

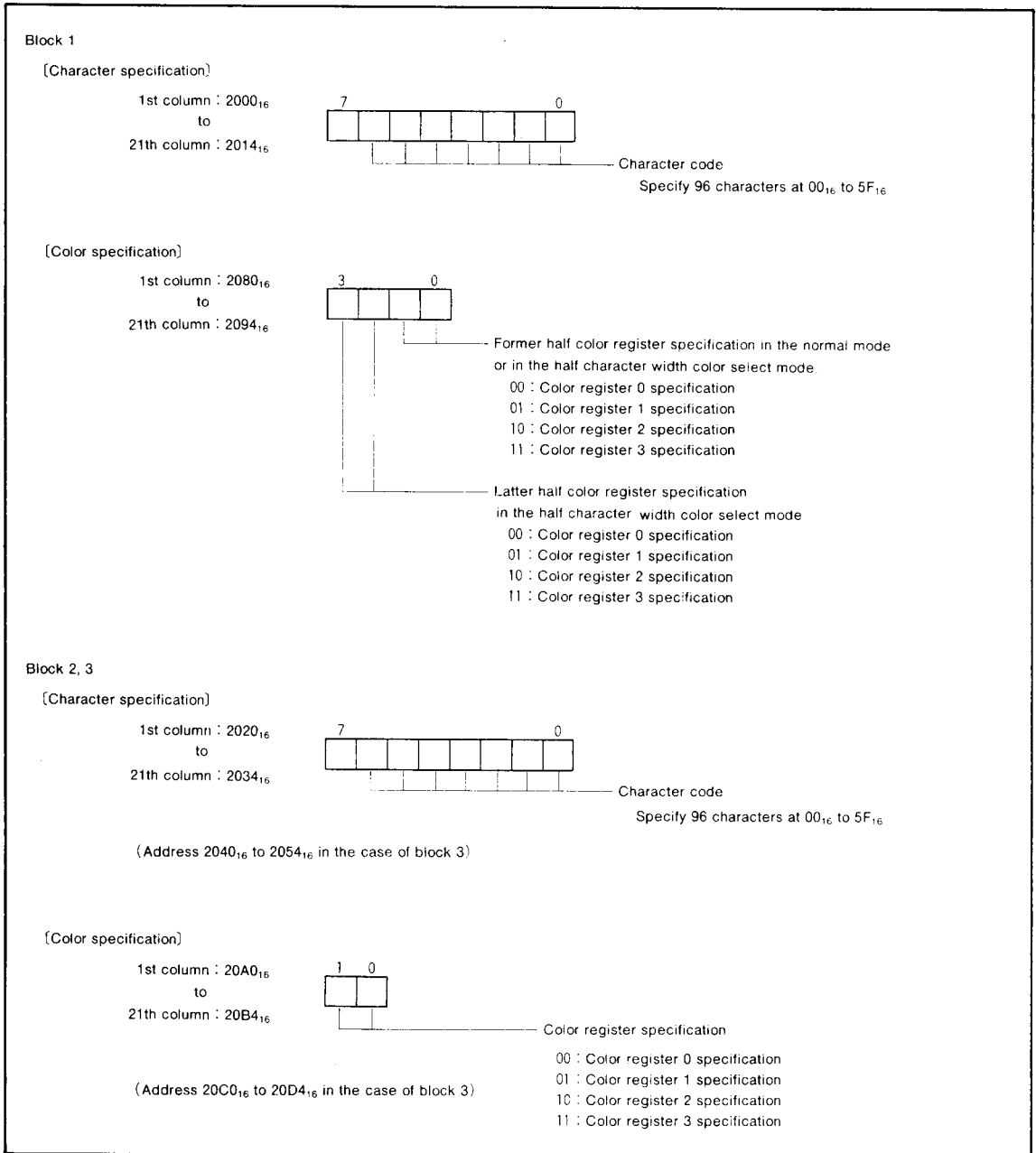

Fig. 26 Structure of the CRT display RAM

**SINGLE-CHIP 8-BIT CMOS MICROCOMPUTER for VOLTAGE SYNTHESIZER  
with ON-SCREEN DISPLAY CONTROLLER**

**(5) Color Registers**

The color of a displayed character can be specified by setting the color to one of the four color registers (CO0-CO3; addresses 00D4<sub>16</sub> to 00D7<sub>16</sub>) and then specifying that color register with the CRT display RAM.

There are four color outputs: R, G, B, and I. By using a combination of these outputs, it is possible to set  $2^4-1$  (when no output) = 15 colors. However, because only four color registers are available, up to four colors can be displayed at one time.

R, G, B, and I outputs are set by using bits 0 to 3 in the color register. Bit 4 in the color register is used to set a character or blank output; bit 5 is used to specify whether a character output or blank output. Figure 27 shows the structure of the color register.

**(6) Half Character Width Color Select Mode**

By setting "1" to bit 4 in the CRT control register (address 00D8<sub>16</sub>) it is possible to specify colors in units of a half character size (vertical 16 dots X horizontal 6 dots) for characters in block 1 only.

In the half character width color select mode, colors of display characters in block 1 are specified as follows:

- ① The left half of the character is set to the color of the color register that is specified by bits 0 and 1 at the color register specifying addresses in the CRT display RAM (addresses 2080<sub>16</sub> to 2094<sub>16</sub>).
- ② The right half of the character is set to the color of the color register that is specified by bits 2 and 3 at the color register specifying address in the CRT display RAM (addresses 2080<sub>16</sub> to 2094<sub>16</sub>).

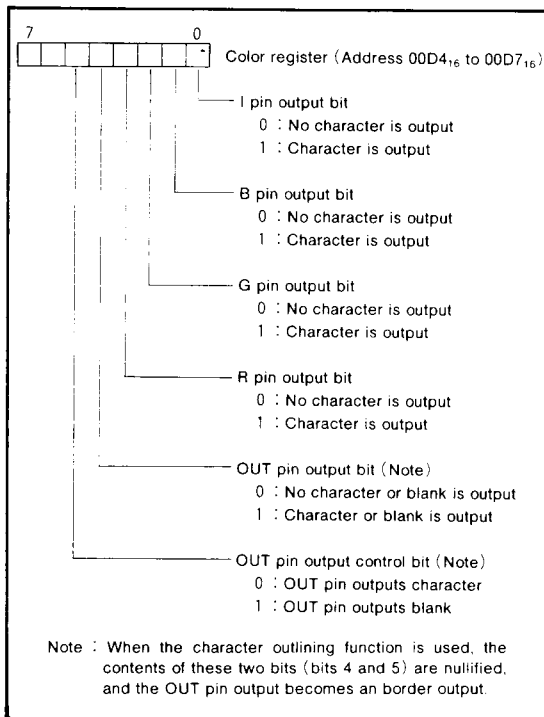

Fig. 27 Structure of color registers

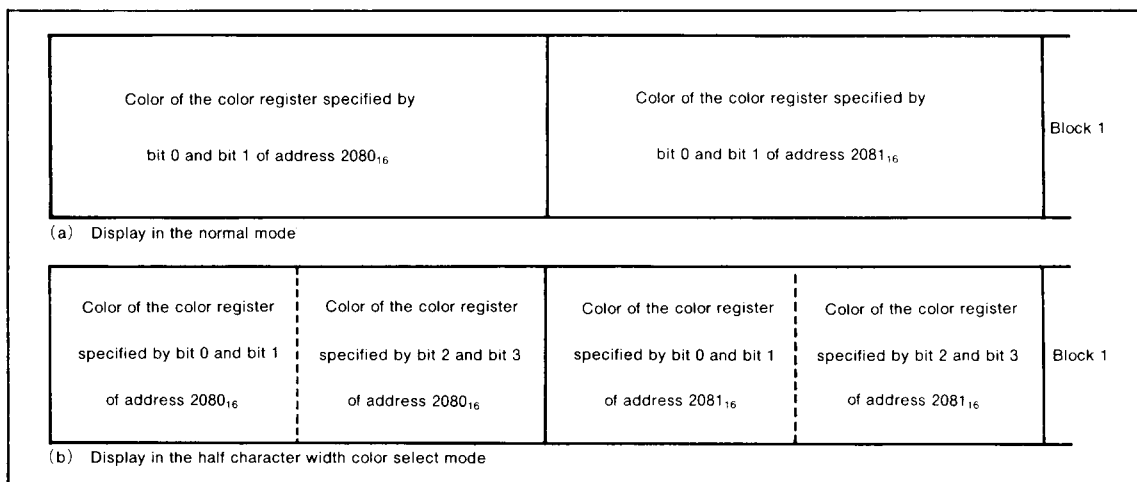

Fig. 28 Difference between normal color select mode and half character width color select mode

**SINGLE-CHIP 8-BIT CMOS MICROCOMPUTER for VOLTAGE SYNTHESIZER  
 with ON-SCREEN DISPLAY CONTROLLER**

**(7) Multiline Display**

The M37103M4-XXXSP can normally display three lines on the CRT screen by displaying three blocks at different vertical positions.

In addition, it allows up to 16 lines to be displayed by using a CRT interrupt and display block counter.

The CRT interrupt works in such a way that when display of one block is terminated, an interrupt request is generated. In other words, character display for a certain block is initiated when the scanning line reaches the display position for that block (specified with vertical and horizontal position registers) and when the range of that block is exceeded, an interrupt is applied.

The display block counter is used to count the number of blocks that have just been displayed. Each time the display of one block is terminated, the contents of the counter are incremented by one.

For multiline display, it is necessary to enable the CRT interrupt (by clearing the interrupt disable flag to "0" and setting the CRT interrupt enable bit=bit 6 at address 00FE<sub>16</sub>) to "1", then execute the following processing in the CRT interrupt handling routine.

- ① Read the value of the display block counter.
  - ② The block for which display is terminated (i.e., the cause of CRT interrupt generation) can be determined by the value read in ①.
  - ③ Replace the display character data and display position of that block with the character data (contents of CRT display RAM) and vertical display position (contents of vertical position register) to be displayed next.
- Figure 29 shows the structure of the display block counter.

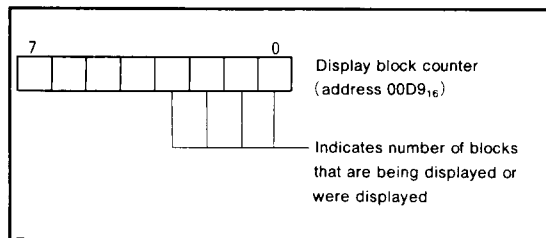

Fig. 29 Structure of display block counter

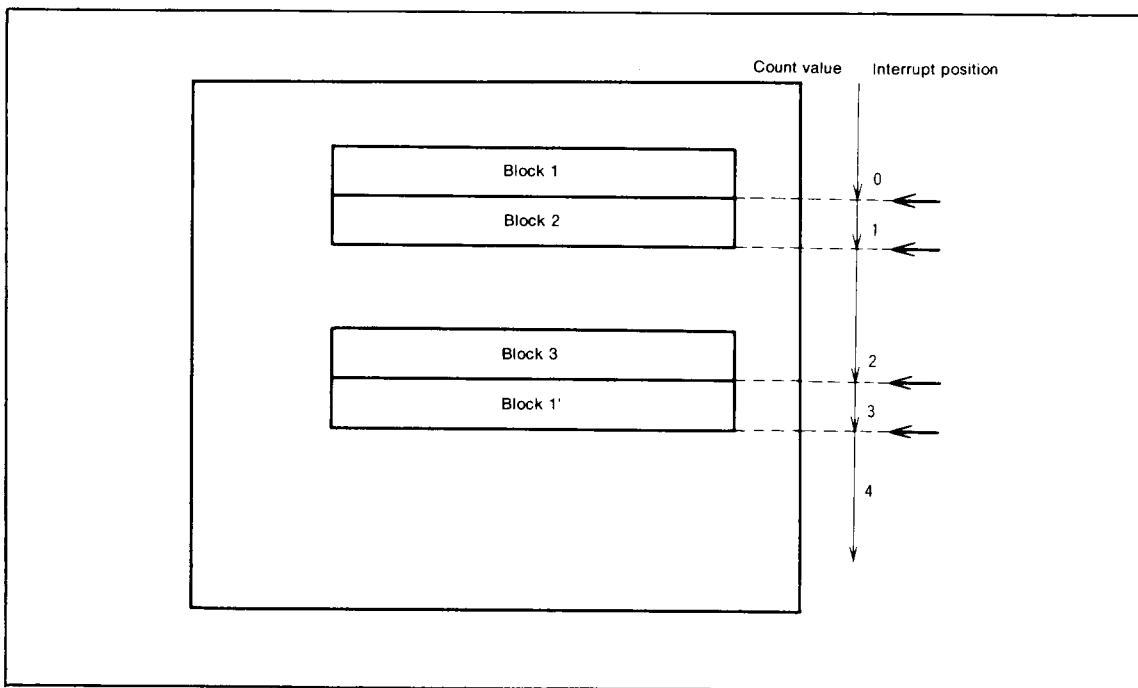

Fig. 30 Timing of CRT interrupt and count value of display block counter

**SINGLE-CHIP 8-BIT CMOS MICROCOMPUTER for VOLTAGE SYNTHESIZER  
with ON-SCREEN DISPLAY CONTROLLER**

**(8) Scanning Line Double Count Mode**

One dot in a displayed character is normally shown by one scanning line. In the scanning line double count mode, one dot can be shown by two scanning lines. As a result, the displayed dot is extended two times the normal size in the vertical direction only. (That is to say, the height of a character is extended twofold.)

In addition, because the scanning line count is doubled, the display start position of a character is also extended twofold in the vertical direction. In other words, whereas the contents set in the vertical position register in the normal mode are 64 steps from  $00_{16}$  to  $3F_{16}$ , or four scanning lines per step, the number of steps in the scanning line double count mode is 32 from  $00_{16}$  to  $1F_{16}$ , or eight scanning lines per step.

If the contents of the vertical position register for a block are set in the address range of  $20_{16}$  to  $3F_{16}$  in the scanning line double count mode, that block cannot be displayed (not output to the CRT screen).

In the scanning line double count mode can be specified by setting bit 6 in the CRT control register (address  $00D8_{16}$ ) to "1".

Because this function works in units of screen, even when the mode is changed the mode about the scanning line count during display of one screen, the double count mode only becomes valid from the time the next screen is displayed.

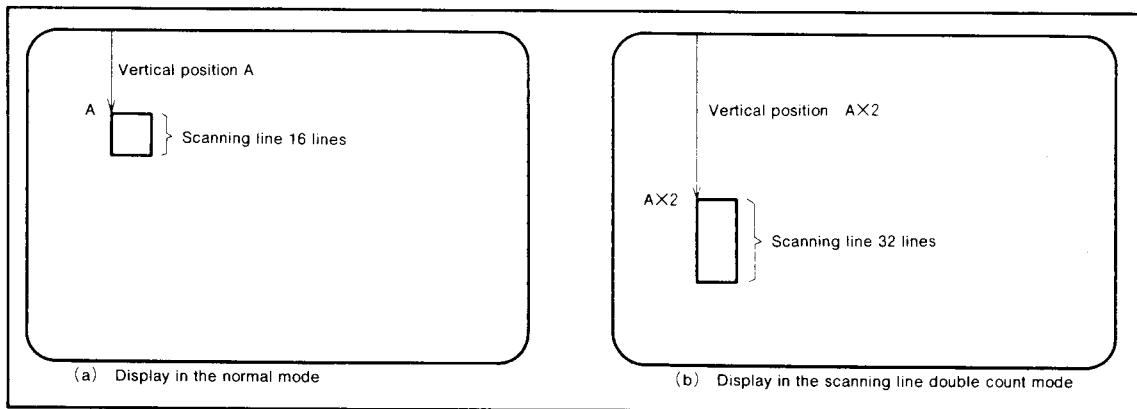

Fig. 31 Display in the normal mode and in the scanning line double count mode

**SINGLE-CHIP 8-BIT CMOS MICROCOMPUTER for VOLTAGE SYNTHESIZER  
with ON-SCREEN DISPLAY CONTROLLER**

**(9) Horizontal Character Border Function**

An border of a one clock (one dot) equivalent size can be added to a character to be displayed only horizontal direction.

The border is output from the OUT pin. In this case, bits 4 and 5 in the color register (contents output from the OUT pin) are nullified, and the border is output from the OUT pin instead.

Border can be specified in units of block by using the bits 6 and 7 of horizontal position register. Table 7 shows the relationship between the values set in the horizontal position register and the character border function.

Table 7. The relationship between the value set in the horizontal position register and the character border function

Horizontal position register		Functions	Example of output	
Bit 7	Bit 6			
X	0	Normal	R, G, B, I output	
0	1	Border including character	R, G, B, I output	
1	1	Border not including character	R, G, B, I output	

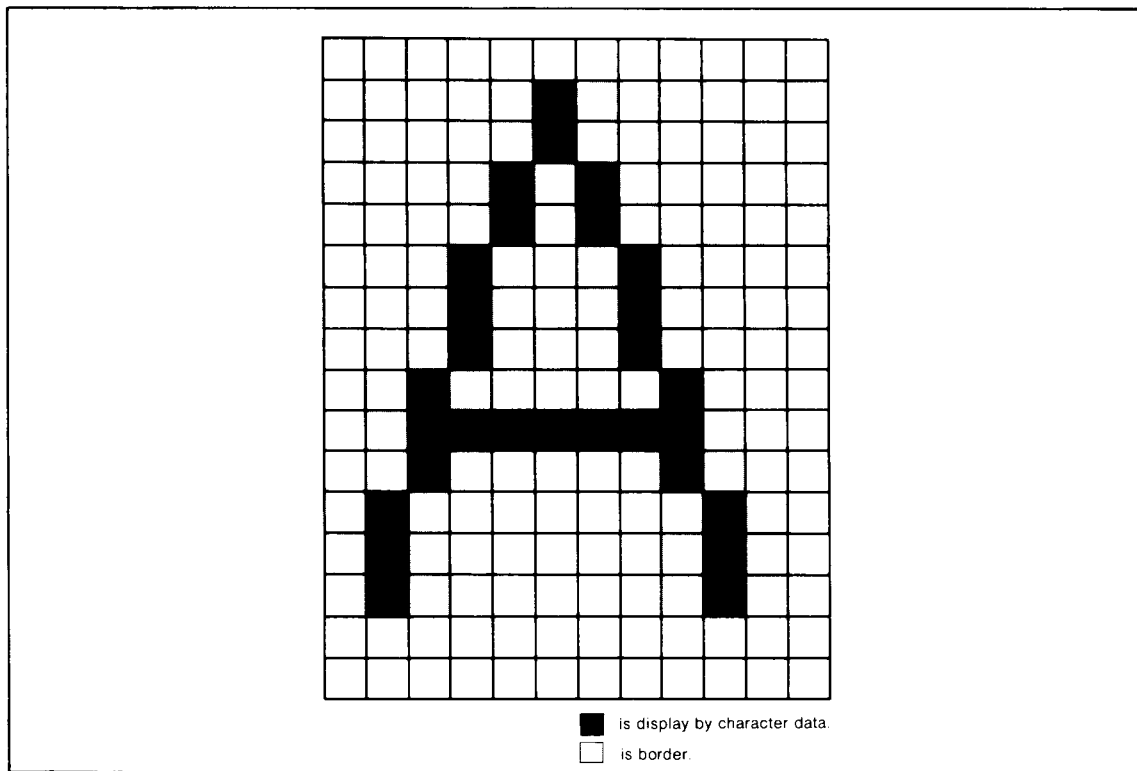

Fig. 32 Example of border



**SINGLE-CHIP 8-BIT CMOS MICROCOMPUTER for VOLTAGE SYNTHESIZER  
with ON-SCREEN DISPLAY CONTROLLER**

---

**(10) Programming notes**

1. Use STA instruction for data transfer to the following registers related to OSD functions.
  - ① Horizontal position register (address 00D0<sub>16</sub>)
  - ② Vertical position registers (address 00D1<sub>16</sub> to 00D3<sub>16</sub>)
  - ③ Color registers (address 00D4<sub>16</sub> to 00D7<sub>16</sub>)
  - ④ CRT control register (address 00D8<sub>16</sub>)
2. Do not display the display OFF blocks having different character sizes on a block display.
3. The highest vertical position (the vertical display start position bits are "00<sub>16</sub>") can not be used.
4. The interrupt to tell the end of block display is not caused and the display block counter is not incremented until the display of the block has been completed terminated.
5. The display block counter (00D9<sub>16</sub>) is reset while V<sub>SYNC</sub> is "H" (when the option is positive in polarity) to "00<sub>16</sub>".
6. If, during the display of a block, the display position of another block comes, the display of the subsequent block (having a larger vertical position register value) is preferred.
7. When two or more blocks are displayed in the same vertical position, the display priority is CV1, CV2, and CV3 in this order. This is not affected by turning on/off of block display.

**SINGLE-CHIP 8-BIT CMOS MICROCOMPUTER for VOLTAGE SYNTHESIZER  
with ON-SCREEN DISPLAY CONTROLLER**

### RESET CIRCUIT

The M37103 is reset according to the sequence shown in Figure 34. It starts the program from the address formed by using the content of address  $FFFF_{16}$  as the high order address and the content of the address  $FFFE_{16}$  as the low order address, when the RESET pin is held at "L" level for no less than  $2\mu s$  while the power voltage is  $5V \pm 10\%$  and the crystal oscillator oscillation is stable and then returned to "H" level. The internal initializations following reset are shown in Figure 33.

	Address	
1: Port P0 directional register	(D0)(E1 <sub>16</sub> )...	00 <sub>16</sub>
2: Port P1 directional register	(D1)(E3 <sub>16</sub> )...	00 <sub>16</sub>
3: Port P2 directional register	(D2)(E5 <sub>16</sub> )...	00 <sub>16</sub>
4: Port P3 directional register	(D3)(E9 <sub>16</sub> )...	00 <sub>16</sub>
5: Port P4 directional register	(D4)(EB <sub>16</sub> )...	0
6: Port P5 directional register	(D5)(ED <sub>16</sub> )...	00000000
7: Port P6 directional register	(D6)(EF <sub>16</sub> )...	00000000
8: PWM control register	(PM)(F5 <sub>16</sub> )...	00 <sub>16</sub>
9: Serial I/O mode register	(SM)(F6 <sub>16</sub> )...	00 <sub>16</sub>
10: PWM output control register	(PN)(F9 <sub>16</sub> )...	00000000
11: Interrupt control register 2	(IN)(FB <sub>16</sub> )...	0
12: Timer 2	(T2)(FC <sub>16</sub> )...	FF <sub>16</sub>
13: Timer 3	(T3)(FD <sub>16</sub> )...	07 <sub>16</sub>
14: Interrupt control register 1	(IM)(FE <sub>16</sub> )...	00 <sub>16</sub>
15: Timer control register	(TM)(FF <sub>16</sub> )...	00 <sub>16</sub>
16: Processor status register	(PS)...	1
17: Program counter	(PC <sub>H</sub> )...	Contents of address FFFF <sub>16</sub>
	(PC <sub>L</sub> )...	Contents of address FFFE <sub>16</sub>
18: Horizontal location register	(HR)(DO <sub>16</sub> )...	00 <sub>16</sub>
19: Color register 0	(CO0)(D4 <sub>16</sub> )...	00000000
20: Color register 1	(CO1)(D5 <sub>16</sub> )...	00000000
21: Color register 2	(CO2)(D6 <sub>16</sub> )...	00000000
22: Color register 3	(CO3)(D7 <sub>16</sub> )...	00000000
23: Display control register	(CC)(D8 <sub>16</sub> )...	00000000
24: PWM output control register	(PQ)(0206 <sub>16</sub> )...	00000000
25: Timer 4 control register	(TN)(0208 <sub>16</sub> )...	000000

Note: Since the contents of both registers other than those listed above and the RAM are undefined at reset, it is necessary to set initial values.

Fig. 33 Internal state of microcomputer at reset

**SINGLE-CHIP 8-BIT CMOS MICROCOMPUTER for VOLTAGE SYNTHESIZER  
with ON-SCREEN DISPLAY CONTROLLER**

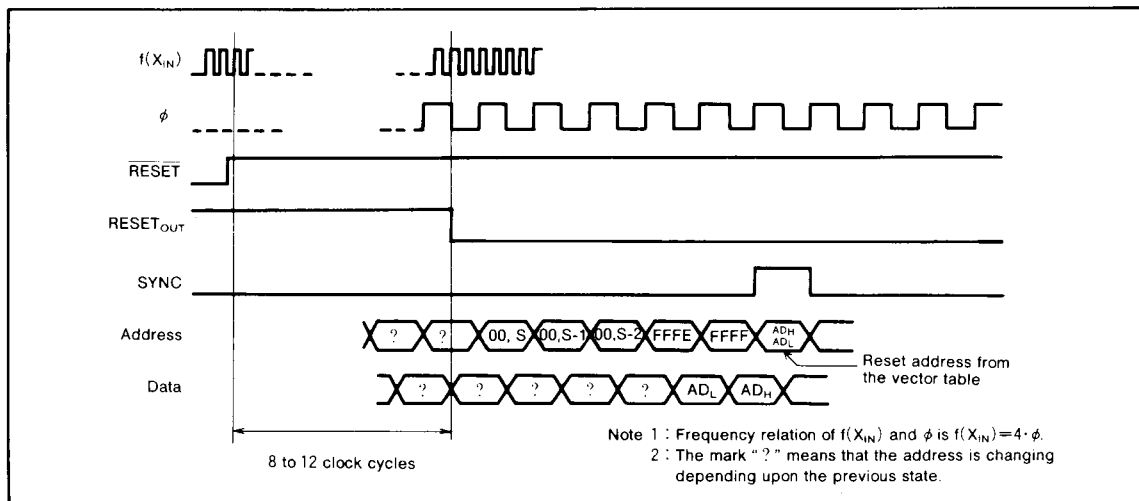

Fig. 34 Timing diagram at reset

**SINGLE-CHIP 8-BIT CMOS MICROCOMPUTER for VOLTAGE SYNTHESIZER  
with ON-SCREEN DISPLAY CONTROLLER**

---

**I/O PORTS**

## (1) Port P0

Port P0 is an 8-bit I/O port with N-channel open drain and middle-voltage output.

As shown in the memory map (Figure 2), port P0 can be accessed at zero page memory address  $00E0_{16}$ .

Port P0 has a directional register (address  $00E1_{16}$ ) which can be used to program each individual bit as input ("0") or as output ("1"). If the pins are programmed as output, the output data is latched to the port register and then output. When data is read from the output port the output pin level is not read, only the latched data in the port register is read. This allows a previously output value to be read correctly even though the output voltage level is shifted up or down. Pins set as input are in the floating state and the signal levels can thus be read. When data is written into the input port, the data is latched only to the port latch and the pin still remains in the floating state.

Depending on the contents of the processor mode bits (bit 0 and bit 1 at address  $00FF_{16}$ ), three different modes can be selected; single-chip mode, eua-chip mode and microprocessor mode.

In these modes it functions as address ( $A_7-A_0$ ) output port (excluding single-chip mode). For more details, see the processor mode information.

## (2) Port P1

In single-chip mode, port P1 has the same function as port P0. It can be built in pull-up register at each pin by selecting the option. In other modes, it functions as address ( $A_{15}-A_8$ ) output port.

Refer to the section on processor modes for details.

## (3) Port P2

In single-chip mode, port P2 has the same function as port P1. In other modes, it functions as data ( $D_0-D_7$ ) input/output port. Refer to the section on processor modes for details.

## (4) Port P3

In single-chip mode, port P3 has the same function as port P0 but the output structure is not middle voltage.  $P3_2-P3_7$  have program selectable dual functions.  $P3_0$ ,  $P3_1$  function as control signals input/output port except in the single-chip mode. Refer to the section on processor modes for details.

## (5) Port P4

This is a 1-bit I/O port with function similar to port P0, but the output structure is CMOS output.

This port is unaffected by the processor mode bits.

## (6) Port P5

This is an 8-bit I/O port with function similar to port P0, but the output structure of  $P5_2$  and  $P5_3$  is not middle-voltage.  $P5_1$  and  $P5_4-P5_7$  have program selectable dual functions.  $P5_2$ ,  $P5_3$  are shared with external interrupt input pins ( $INT_1$ ,  $INT_2$ ).

This port is unaffected by the processor mode bits.

## (7) Port P6

This is an 6-bit input/output port with function similar to port P0. The output structure of  $P6_0$ ,  $P6_1$  is CMOS output and the output structure of  $P6_2-P6_5$  is N-channel open drain and middle-voltage.

$P6_0-P6_5$  have program selectable dual functions.

This port is unaffected by the processor mode bits.

## (8) Function pins for CRT display function.

The horizontal synchronizing signal is input from  $H_{SYNC}$ . The vertical synchronizing signal is input from  $V_{SYNC}$ . I, B, G, R, OUT are output pins for CRT display.

Refer to the section on CRT display functions for details.

(9)  $\phi$  pin.

The internal system clock (1/4 the frequency of the oscillator connected between the  $X_{IN}$  and  $X_{OUT}$  pins) can be output from this pin by selecting the option.

At low-speed mode,  $X_{CIN}$  divided by 2 is output from this pin.

**SINGLE-CHIP 8-BIT CMOS MICROCOMPUTER for VOLTAGE SYNTHESIZER  
 with ON-SCREEN DISPLAY CONTROLLER**

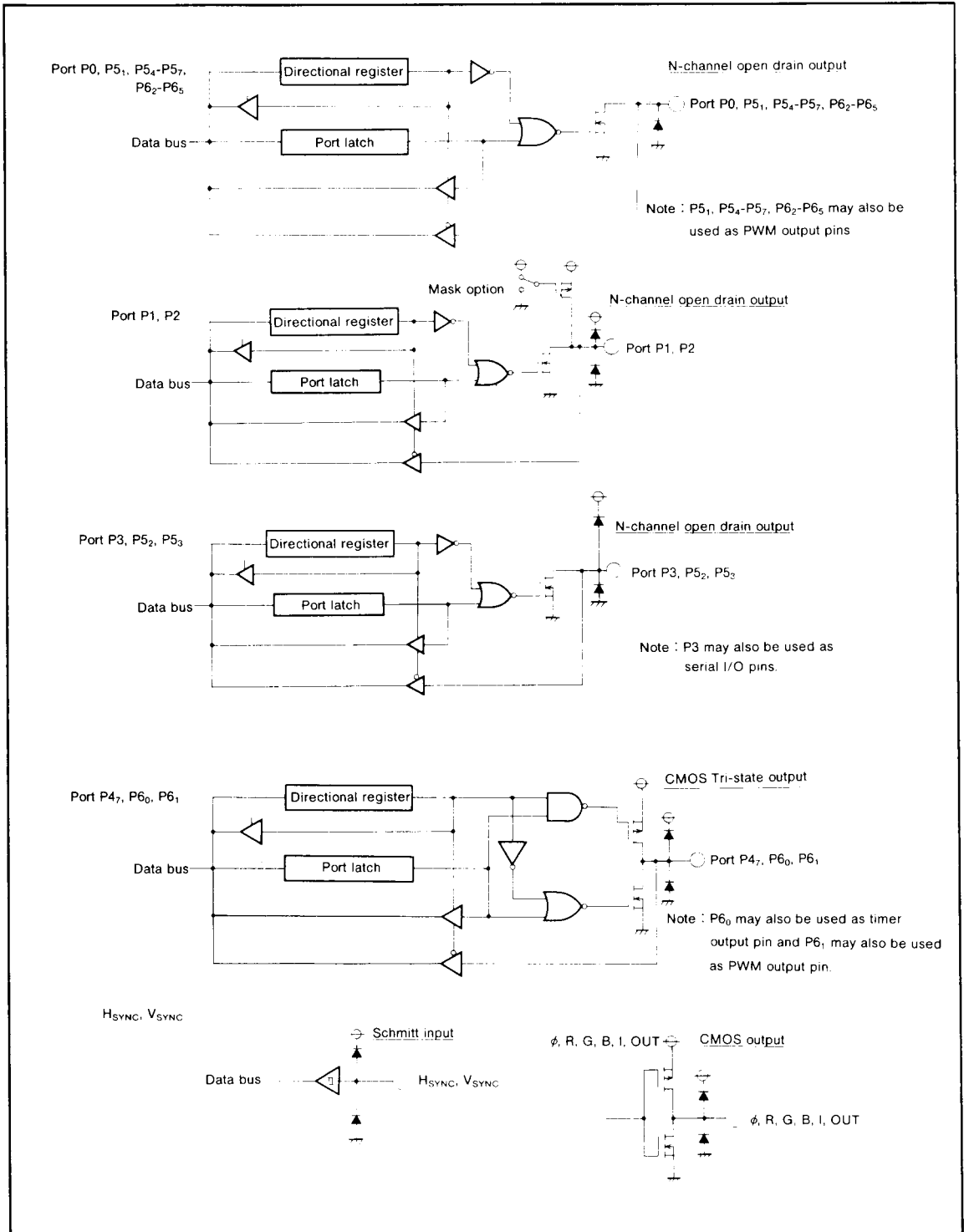

Fig. 35 Ports P0-P6, H<sub>SYNC</sub>, V<sub>SYNC</sub>, φ, R, G, B, I and OUT block diagram

**SINGLE-CHIP 8-BIT CMOS MICROCOMPUTER for VOLTAGE SYNTHESIZER  
with ON-SCREEN DISPLAY CONTROLLER**

**PROCESSOR MODE**

By changing the contents of the processor mode bit (bit 0 and 1 at address 00FF<sub>16</sub>), three different operation modes can be selected; single-chip mode, microprocessor mode and evaluation chip (eva-chip) mode. In the microprocessor mode and eva-chip mode, ports P0-P3 can be used as multiplexed I/O for address, data and control signals, as well as the normal functions of the I/O ports.

Figure 37 shows the functions of ports P0-P3.

The memory map for the single-chip mode is illustrated in Figure 1 and for other modes, in Figure 36.

By connecting CNV<sub>SS</sub> to V<sub>SS</sub>, all three modes can be selected through software by changing the processor mode bits. Supplying 10V to CNV<sub>SS</sub> places the microcomputer in the eva-chip mode. The three different modes are explained as follows:

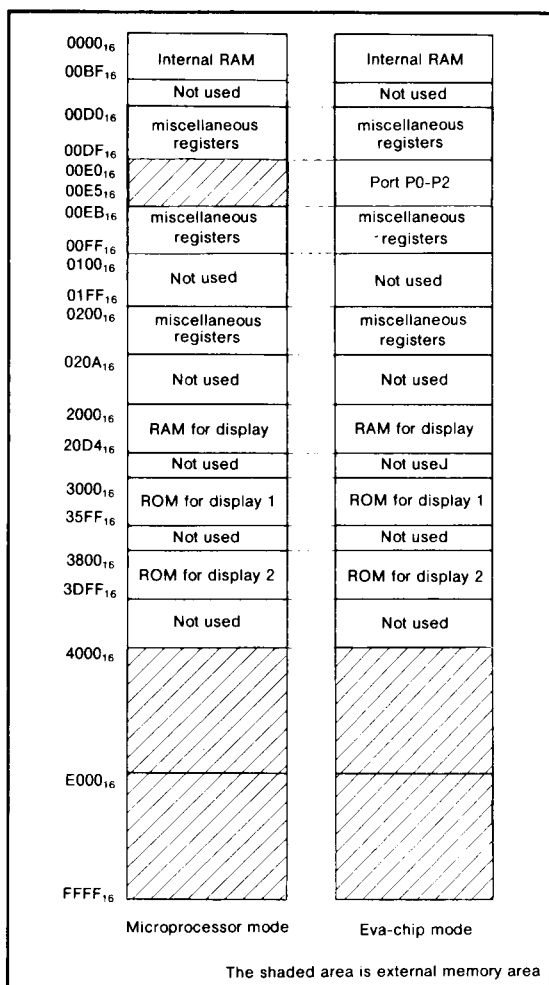

Fig. 36 Example memory area in processor mode

(1) Single-chip mode [00]

The microcomputer will automatically be in the single-chip mode when started from reset, if CNV<sub>SS</sub> is connected to V<sub>SS</sub>. Port P0-P3 will work as original I/O ports.

(2) Microprocessor mode [01]

The microcomputer will be placed in the microprocessor mode when CNV<sub>SS</sub> is connected to V<sub>SS</sub> and the processor mode bits are set to "01".

In this mode, the internal ROM is inhibited so the external memory is required.

In this mode, port P0 and P1 are used as the system address bus and the original function of the I/O pins is lost. Port P2 becomes the data bus (D<sub>7</sub>-D<sub>0</sub>) and loses its normal output functions. Port P3<sub>1</sub> and P3<sub>0</sub> become the SYNC and R/W pins, respectively and the normal I/O functions are lost.

(3) Eva-chip mode [11]

When 10V is supplied to CNV<sub>SS</sub> pin, the microcomputer is forced into the eva-chip mode.

In this mode, the internal ROM is inhibited so the external memory is required.

The lower 8 bits of address data for port P0 is output when φ goes to "H" state. When φ goes to the "L" state, P0 retains its original output functions.

Port P1's higher 8 bits of address data are output when φ goes to "H" state and as it changes back to the "L" state it retains its original output functions. Port P2 retains its original output functions while φ is at the "H" state, and works as a data bus of D<sub>7</sub>-D<sub>0</sub> (including instruction code) while at the "L" state. Pins P3<sub>1</sub> and P3<sub>0</sub> output the SYNC and R/W control signals, respectively while φ is in the "H" state. When in the "L" state, P3<sub>1</sub> and P3<sub>0</sub> retain their original I/O function.

The R/W output is used to read/write from/to the outside. When this pin is in the "H" state, the CPU reads data, and when in the "L" state, the CPU writes data.

The SYNC is a synchronous signal which goes to the "H" state when it fetches the OP CODE.

The relationship between the input level of CNV<sub>SS</sub> and the processor mode is shown in Table 8.

Note : Use the M37103M4-XXXSP in the microprocessor mode or the memory expanding mode only at program development.

The standards is assured only in the single-chip mode.

**SINGLE-CHIP 8-BIT CMOS MICROCOMPUTER for VOLTAGE SYNTHESIZER  
with ON-SCREEN DISPLAY CONTROLLER**

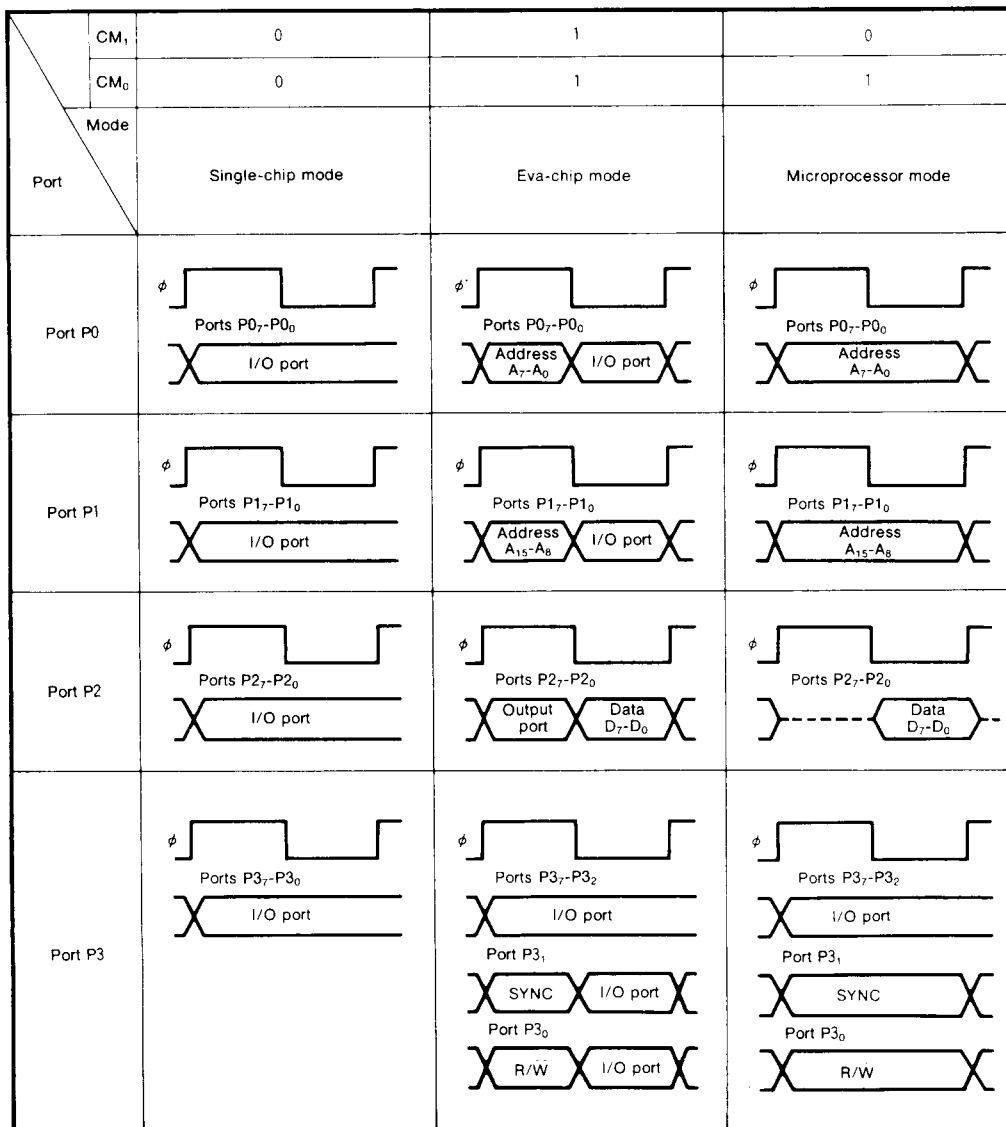

Fig. 37 Processor mode and functions of ports P0-P3

Table 8. Relationship between CNV<sub>SS</sub> pin input level and processor mode

CNV <sub>SS</sub>	Mode	Explanation
V <sub>SS</sub>	<ul style="list-style-type: none"> <li>• Single-chip mode</li> <li>• Eva-chip mode</li> <li>• Microprocessor mode</li> </ul>	The single-chip mode is set by the reset. All modes can be selected by changing the processor mode bit with the program.
10V	<ul style="list-style-type: none"> <li>• Eva-chip mode</li> </ul>	Eva-chip mode only.

**SINGLE-CHIP 8-BIT CMOS MICROCOMPUTER for VOLTAGE SYNTHESIZER  
 with ON-SCREEN DISPLAY CONTROLLER**

**CLOCK GENERATING CIRCUIT**

The M37103M4-XXXSP has two internal clock generating circuits. Figure 40 shows a block diagram of the clock generating circuits. Normally, the frequency applied to the clock input pin  $X_{IN}$  divided by four is used as the internal clock (timing output)  $\phi$ . Bit 7 of serial I/O mode register can be used to switch the internal clock  $\phi$  to 1/2 the frequency applied to the clock input pin  $X_{CIN}$ .

Figure 38 shows a circuit example using a ceramic (or crystal) oscillator. Use the manufacturer's recommended values for constants such as capacitance which will differ depending on each oscillator. When using an external clock signal, input from the  $X_{IN}$  ( $X_{CIN}$ ) pin and leave the  $X_{OUT}$  ( $X_{COUT}$ ) pin open. A circuit example is shown in Figure 39.

The M37103M4-XXXSP has two low power dissipation modes; stop and wait. The microcomputer enters a stop mode when the STP instruction is executed. The oscillator (both  $X_{IN}$  clock and  $X_{CIN}$  clock) stops with the internal clock  $\phi$  held at "H" level. In this case timer 2 and timer 3 are forcibly connected and  $\phi/8$  is selected as timer 2 input. When restarting oscillation,  $FF_{16}$  is automatically set in timer 2 and  $07_{16}$  in timer 3 in order to enable the oscillator to stabilize. Before executing the STP instruction, the timer 2 count stop bit must be set to supply ("0"), timer 2 interrupt enable bit and timer 3 interrupt enable bit must be set to disable ("0").

Oscillation is restarted (release the stop mode) when  $INT_1$ ,  $INT_2$ , or serial I/O interrupt is received. The interrupt enable bit of the interrupt used to release the stop mode must be set to "1". When restarting oscillation with an interrupt or reset, the internal clock  $\phi$  is held "H" until timer 3 overflows and is not supplied to the CPU.

The microcomputer enters a wait mode when the WIT instruction is executed. The internal clock  $\phi$  stops at "H" level, but the oscillator does not stop.  $\phi$  is re-supplied (wait mode release) when the microcomputer is reset or when it receives an interrupt.

Instructions can be executed immediately because the oscillator is not stopped. The interrupt enable bit of the interrupt used to reset the wait mode must be set to "1" before executing the WIT instruction.

Low power dissipation operation is also achieved when the  $X_{IN}$  clock is stopped and the internal clock  $\phi$  is generated from the  $X_{CIN}$  clock ( $60\mu A$  or less at  $f(X_{CIN})=32kHz$ ).  $X_{IN}$  clock oscillation is stopped when the bit 6 of serial I/O mode register (address  $00F6_{16}$ ) is set and restarted when it is cleared. However, the wait time until the oscillation stabilizes must be generated with a program when restarting. Figure 41 shows the transition of states for the system clock.

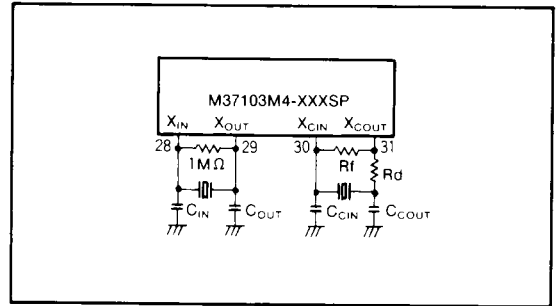

Fig. 38 Example ceramic resonator circuit

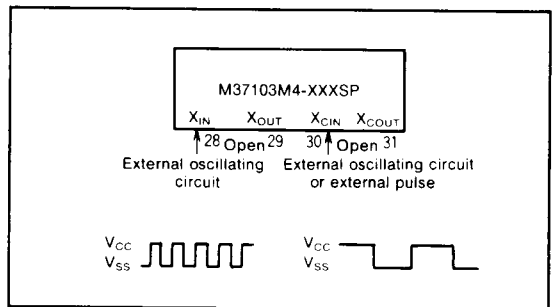

Fig. 39 Example clock input circuit



**SINGLE-CHIP 8-BIT CMOS MICROCOMPUTER for VOLTAGE SYNTHESIZER  
 with ON-SCREEN DISPLAY CONTROLLER**

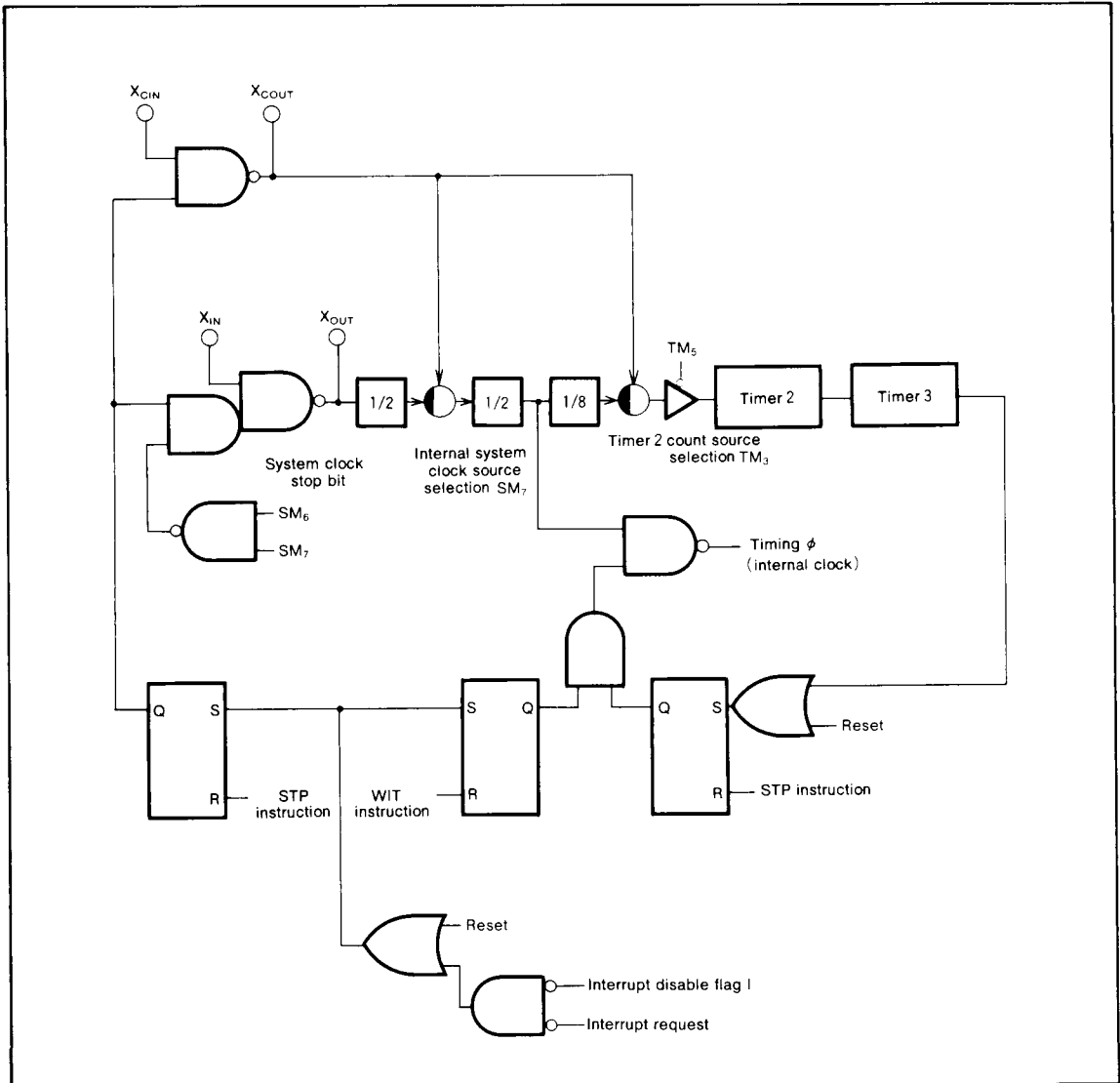

Fig. 40 Block diagram of clock generating circuit

**SINGLE-CHIP 8-BIT CMOS MICROCOMPUTER for VOLTAGE SYNTHESIZER  
with ON-SCREEN DISPLAY CONTROLLER**

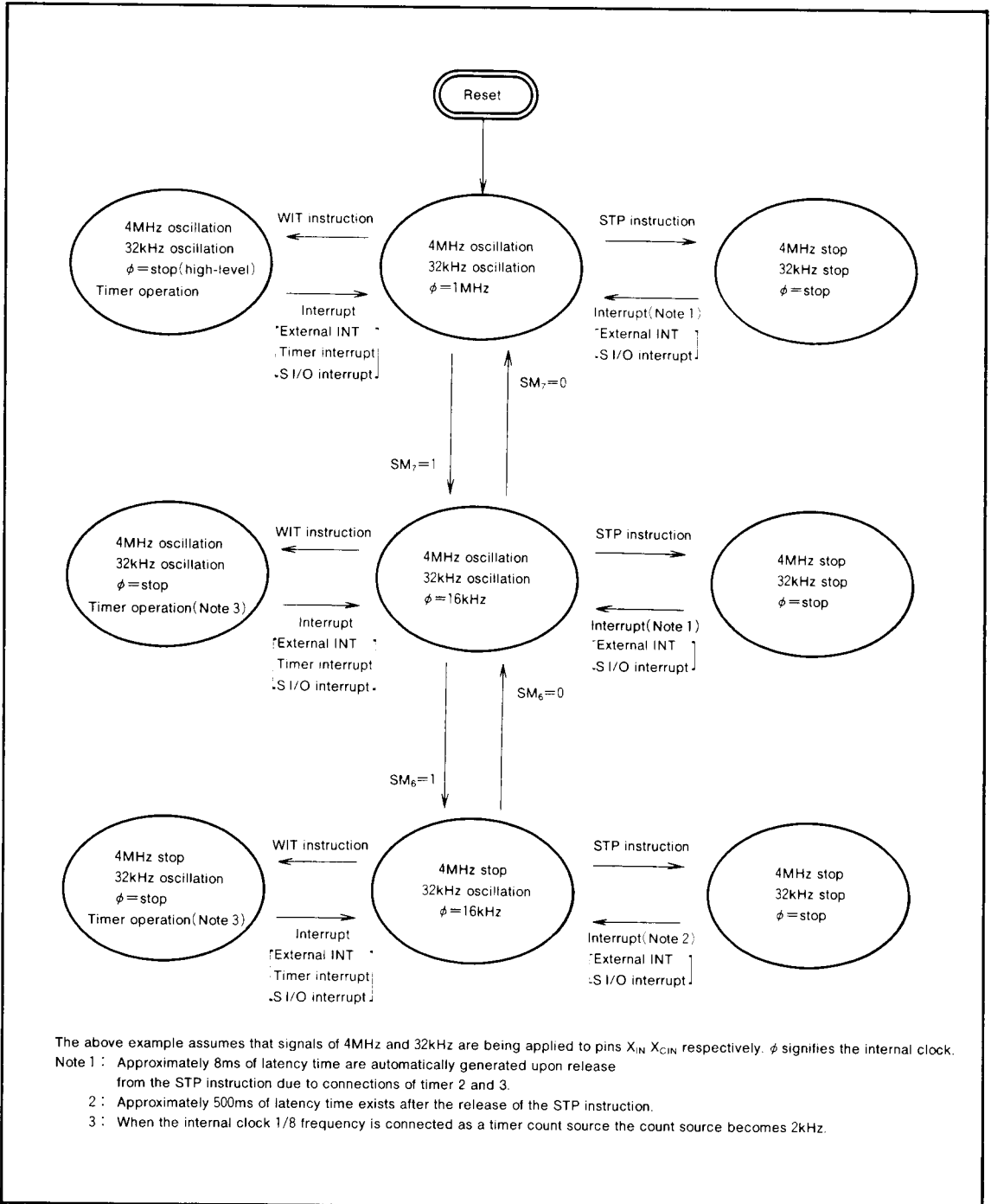
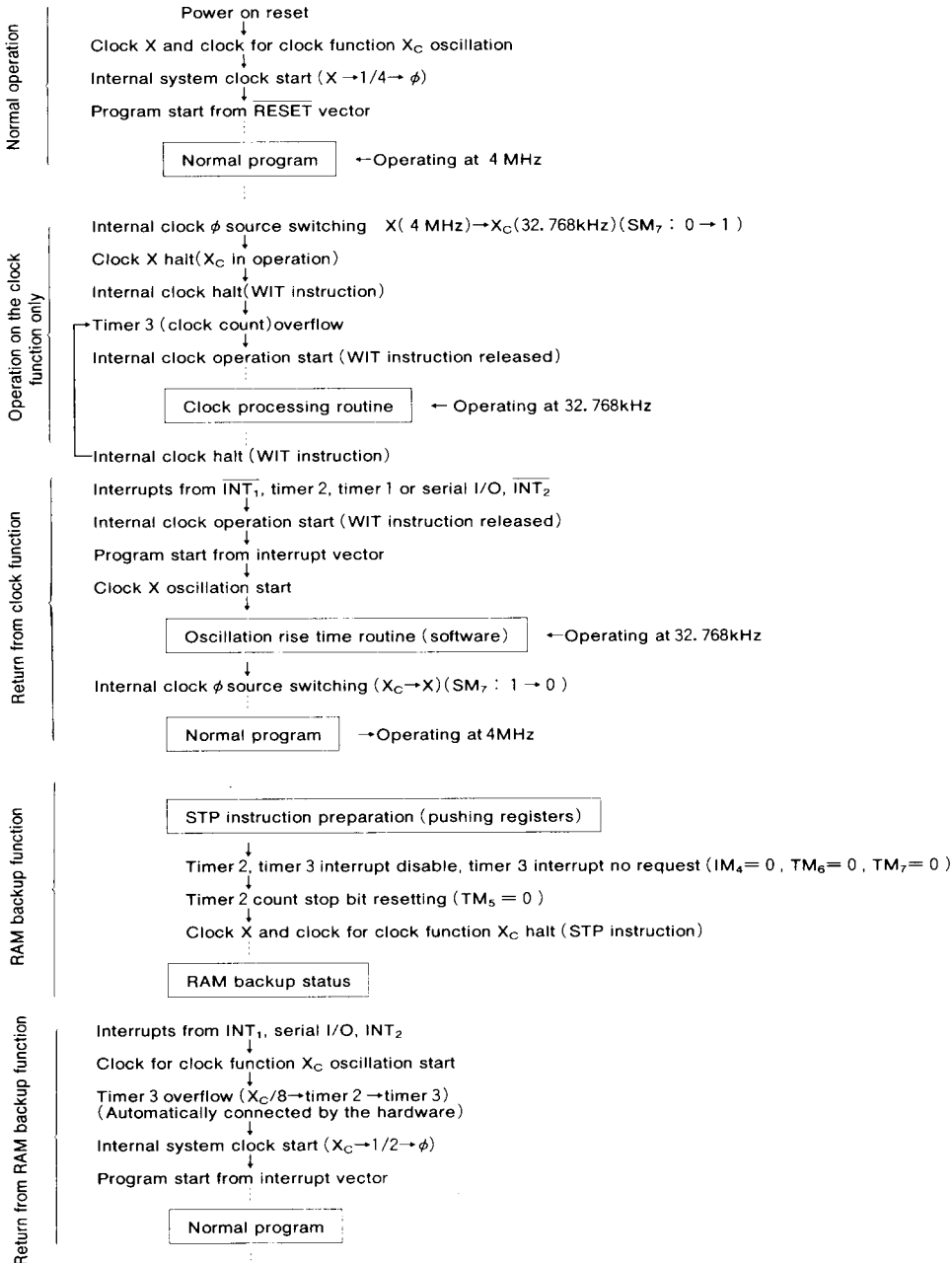

Fig. 41 Transition of states for the system clock

**SINGLE-CHIP 8-BIT CMOS MICROCOMPUTER for VOLTAGE SYNTHESIZER  
with ON-SCREEN DISPLAY CONTROLLER**

<An example of flow for system>



**SINGLE-CHIP 8-BIT CMOS MICROCOMPUTER for VOLTAGE SYNTHESIZER  
with ON-SCREEN DISPLAY CONTROLLER**

---

**PROGRAMMING NOTES**

- (1) Processor status register
  1. Except for the interrupt inhibit flag ( I ) being set to "1", the content of the processor status register (PS) is unpredictable after a reset. Therefore, flags affecting program execution must be initialized.  
The T flag and D flag which affect arithmetic operations, must always be initialized.
  2. A NOP instruction must be used after the execution of a PLP instruction.
- (2) Interrupts  
Even though the BBC and BBS instructions are executed just after the interrupt request bits are modified (by the program), those instructions are only valid for the contents before the modification. Also, at least one instruction cycle must be used (such as a NOP) between the modification of the interrupt request bits and the execution of the BBC and BBS instructions.
- (3) Decimal operations
  1. Decimal operations are performed by setting the decimal mode flag (D) and executing the ADC or SBC instruction. In this case, there must be at least one instruction following the ADC or SBC instruction before executing the SEC, CLC, or CLD instruction.
  2. The N (Negative), V (Overflow), and Z (Zero) flags are ignored during decimal mode.
- (4) Timers  
The frequency dividing ratio of timer is  $1/(n+1)$ .
- (5) STP instruction  
The STP instruction must be executed after setting the timer 2 count stop bit (bit 5 at address 00FF<sub>16</sub>) to supply ("0").

**DATA REQUIRED FOR MASK ORDERING**

Please send the following data for mask orders.

- mask ROM order confirmation form
- mark specification form
- ROM data.....EPROM 3 sets

Write the following option on the mark confirmation form

- (1) Port P1 pull-up transistor bit
- (2) Port P2 pull-up transistor bit
- (3) X<sub>IN</sub> and X<sub>CIN</sub> oscillation feed-back resistor
- (4) CRT display signal input/output polarity
- (5)  $\phi$  output

**SINGLE-CHIP 8-BIT CMOS MICROCOMPUTER for VOLTAGE SYNTHESIZER  
with ON-SCREEN DISPLAY CONTROLLER**

**ABSOLUTE MAXIMUM RATINGS**

Symbol	Parameter	Conditions	Ratings	Unit
V <sub>CC</sub>	Supply voltage		-0.3 to 6	V
V <sub>I</sub>	Input voltage RESET, CNV <sub>SS</sub>		-0.3 to 13	V
V <sub>I</sub>	Input voltage P0 <sub>0</sub> -P0 <sub>7</sub> , P1 <sub>0</sub> -P1 <sub>7</sub> , P2 <sub>0</sub> -P2 <sub>7</sub> , P3 <sub>0</sub> -P3 <sub>7</sub> , P4 <sub>7</sub> , P5 <sub>1</sub> -P5 <sub>7</sub> , P6 <sub>0</sub> -P6 <sub>5</sub> , H <sub>SYNC</sub> , V <sub>SYNC</sub> , X <sub>IN</sub> , X <sub>CIN</sub> , OSC1	With respect to V <sub>SS</sub> Output transistors are at "off" state.	-0.3 to V <sub>CC</sub> +0.3	V
V <sub>O</sub>	Output voltage P0 <sub>0</sub> -P0 <sub>7</sub> , P5 <sub>1</sub> , P5 <sub>4</sub> -P5 <sub>7</sub> , P6 <sub>2</sub> -P6 <sub>5</sub>		-0.3 to 13	V
V <sub>O</sub>	Output voltage P1 <sub>0</sub> -P1 <sub>7</sub> , P2 <sub>0</sub> -P2 <sub>7</sub> , P3 <sub>0</sub> -P3 <sub>7</sub> , P4 <sub>7</sub> , P5 <sub>2</sub> , P5 <sub>3</sub> , P6 <sub>0</sub> , P6 <sub>1</sub> , X <sub>OUT</sub> , φ, X <sub>COUT</sub> , OSC2, R, G, B, I, OUT		-0.3 to V <sub>CC</sub> +0.3	V
I <sub>OH</sub>	Circuit current P6 <sub>0</sub> , P6 <sub>1</sub> , P4 <sub>7</sub> , R, G, B, I, OUT		0 to 10 (Note 1)	mA
I <sub>OL1</sub>	Circuit current P1 <sub>0</sub> -P1 <sub>7</sub> , P2 <sub>0</sub> -P2 <sub>7</sub> , P3 <sub>0</sub> -P3 <sub>7</sub> , P4 <sub>7</sub> , P5 <sub>2</sub> , P5 <sub>3</sub> , P6 <sub>0</sub> , P6 <sub>1</sub> , R, G, B, I, OUT		0 to 15 (Note 2)	mA
I <sub>OL2</sub>	Circuit current P0 <sub>0</sub> -P0 <sub>7</sub> , P5 <sub>1</sub> , P5 <sub>4</sub> -P5 <sub>7</sub> , P6 <sub>2</sub> -P6 <sub>5</sub>	V <sub>0</sub> ≤ 7V V <sub>0</sub> > 7V	0 to 15 (Note 2) 0 to 1 (Note 2)	mA
P <sub>d</sub>	Power dissipation	T <sub>a</sub> = 25°C	1000	mW
T <sub>opr</sub>	Operating temperature		-10 to 70	°C
T <sub>stg</sub>	Storage temperature		-40 to 125	°C

Note 1 : The total of I<sub>OH</sub> should be 20mA(max.).

2 : The total of I<sub>OL1</sub> and I<sub>OL2</sub> should be 50mA(max.).

**RECOMMENDED OPERATING CONDITIONS**

(V<sub>CC</sub>=5V±10%, T<sub>a</sub>=-10 to 70°C unless otherwise noted)

Symbol	Parameter		Limits			Unit
			Min.	Typ.	Max.	
V <sub>CC</sub>	Supply voltage (Note 1)	Normal speed mode f(X <sub>IN</sub> )=4MHz f(OSC1)=5MHz	4.5	5.0	5.5	V
		Low-speed mode f(X <sub>CIN</sub> )=32kHz	3.0	5.0	5.5	
V <sub>SS</sub>	Supply voltage		0	0	0	V
V <sub>IH</sub>	"H" input voltage P0 <sub>0</sub> -P0 <sub>7</sub> , P1 <sub>0</sub> -P1 <sub>7</sub> , P2 <sub>0</sub> -P2 <sub>7</sub> , P3 <sub>0</sub> -P3 <sub>7</sub> , P4 <sub>7</sub> , P5 <sub>1</sub> -P5 <sub>7</sub> , P6 <sub>0</sub> -P6 <sub>5</sub> , X <sub>IN</sub> , X <sub>CIN</sub> , RESET, H <sub>SYNC</sub> , V <sub>SYNC</sub>		0.8V <sub>CC</sub>		V <sub>CC</sub>	V
V <sub>IL</sub>	"L" input voltage P0 <sub>0</sub> -P0 <sub>7</sub> , P1 <sub>0</sub> -P1 <sub>7</sub> , P2 <sub>0</sub> -P2 <sub>7</sub> , P3 <sub>0</sub> , P3 <sub>1</sub> , P3 <sub>3</sub> -P3 <sub>5</sub> , P3 <sub>7</sub> , P4 <sub>7</sub> , P5 <sub>1</sub> , P5 <sub>4</sub> , P5 <sub>5</sub> , P5 <sub>7</sub> , P6 <sub>0</sub> -P6 <sub>5</sub>		0		0.4V <sub>CC</sub>	V
V <sub>IL</sub>	"L" input voltage P3 <sub>2</sub> , P3 <sub>6</sub> , P5 <sub>2</sub> , P5 <sub>3</sub> , P5 <sub>6</sub> , RESET, X <sub>IN</sub> , X <sub>CIN</sub> , H <sub>SYNC</sub> , V <sub>SYNC</sub>		0		0.2V <sub>CC</sub>	V
I <sub>OL</sub> (avg)	"L" average output current P0 <sub>0</sub> -P0 <sub>7</sub> , P1 <sub>0</sub> -P1 <sub>7</sub> , P2 <sub>0</sub> -P2 <sub>7</sub> , P3 <sub>0</sub> -P3 <sub>7</sub> , P4 <sub>7</sub> , P5 <sub>1</sub> -P5 <sub>7</sub> , P6 <sub>0</sub> -P6 <sub>5</sub> , R, G, B, I, OUT				5	mA
I <sub>OL</sub> (avg)	"L" average output current P0 <sub>0</sub> -P0 <sub>7</sub> , P5 <sub>1</sub> , P5 <sub>4</sub> -P5 <sub>7</sub> , P6 <sub>2</sub> -P6 <sub>5</sub>	V <sub>0</sub> ≤ 7V			5	mA
		V <sub>0</sub> > 7V			1	
I <sub>OH</sub> (avg)	"H" average output current P4 <sub>7</sub> , P6 <sub>0</sub> , P6 <sub>1</sub> , R, G, B, I, OUT				2	mA
f(X <sub>IN</sub> )	Oscillating frequency (Note 2)		3.6	4	4.4	MHz
f(X <sub>CIN</sub> )	Oscillating frequency		29	32	35	kHz
f(OSC1)	Oscillating frequency		4	5	6	MHz

Note 1 : Apply 0.022μF or greater capacitance externally to the V<sub>CC</sub> power supply pin so as to reduce power source noise.

2 : Use a quartz crystal oscillator or a ceramic resonator for the CPU oscillating circuit.

**SINGLE-CHIP 8-BIT CMOS MICROCOMPUTER for VOLTAGE SYNTHESIZER  
with ON-SCREEN DISPLAY CONTROLLER**

**ELECTRIC CHARACTERISTICS** ( $V_{CC}=5V\pm 10\%$ ,  $V_{SS}=0V$ ,  $T_a=-10$  to  $70^\circ C$ ,  $f(X_{IN})=4MHz$ )

Symbol	Parameter	Test conditions	Limits			Unit
			Min.	Typ.	Max.	
$V_{OH}$	"H" output voltage P4 <sub>7</sub> , P6 <sub>0</sub> , P6 <sub>1</sub> , R, G, B, I, OUT	$V_{CC}=4.5V$ , $I_{OH}=-0.5mA$	2.4			V
$V_{OH}$	"H" output voltage $\phi$	$V_{CC}=4.5V$ $I_{OH}=-2.5mA$	2.4			V
$V_{OL}$	"L" output voltage P0 <sub>0</sub> -P0 <sub>7</sub> , P2 <sub>0</sub> -P2 <sub>7</sub> , P3 <sub>0</sub> -P3 <sub>7</sub> , P4 <sub>7</sub> , P5 <sub>1</sub> -P5 <sub>7</sub> , P6 <sub>0</sub> -P6 <sub>5</sub> , R, G, B, I, OUT	$V_{CC}=4.5V$ $I_{OL}=0.5mA$			0.4	V
$V_{OL}$	"L" output voltage P1 <sub>0</sub> -P1 <sub>7</sub>	$V_{CC}=4.5V$ $I_{OL}=10mA$			1.5	V
$V_{OL}$	"L" output voltage $\phi$	$V_{CC}=4.5V$ $I_{OL}=2.5mA$			2	V
$V_{T+} - V_{T-}$	Hysteresis F, ESET	$V_{CC}=5.0V$		0.5	0.7	V
$V_{T+} - V_{T-}$	Hysteresis P3 <sub>2</sub> , P3 <sub>6</sub> , P4 <sub>7</sub> , P5 <sub>2</sub> , P5 <sub>3</sub> , P5 <sub>6</sub> , H <sub>SYNC</sub> , V <sub>SYNC</sub> , X <sub>CIN</sub> (Note 2)	$V_{CC}=5.0V$		0.5	1.3	V
$R_U$	Pull-up transistor (Note 1) P1 <sub>0</sub> -P1 <sub>7</sub> , P2 <sub>0</sub> -P2 <sub>7</sub>	$V_{CC}=5.0V$ $V_I=0V$	15	30	60	k $\Omega$
$I_{OZH}$	"H" input current P0 <sub>0</sub> -P0 <sub>7</sub> , P1 <sub>0</sub> -P1 <sub>7</sub> , P2 <sub>0</sub> -P2 <sub>7</sub> , P3 <sub>0</sub> -P3 <sub>7</sub> , P4 <sub>7</sub> , P5 <sub>1</sub> -P5 <sub>7</sub> , P6 <sub>0</sub> -P6 <sub>5</sub> , RESET, X <sub>IN</sub> , X <sub>CIN</sub> , H <sub>SYNC</sub> , V <sub>SYNC</sub>	$V_{CC}=5.5V$ $V_O=5.5V$			5	$\mu A$
$I_{OZH}$	"H" input leak current P0 <sub>0</sub> -P0 <sub>7</sub> , P5 <sub>1</sub> , P5 <sub>4</sub> -P5 <sub>7</sub> , P6 <sub>0</sub> -P6 <sub>5</sub>	$V_{CC}=5.5V$ $V_O=12V$			10	$\mu A$
$I_{OZL}$	"L" input leak current P0 <sub>0</sub> -P0 <sub>7</sub> , P1 <sub>0</sub> -P1 <sub>7</sub> , P2 <sub>0</sub> -P2 <sub>7</sub> , P3 <sub>0</sub> -P3 <sub>7</sub> , P4 <sub>7</sub> , P5 <sub>1</sub> -P5 <sub>7</sub> , P6 <sub>0</sub> -P6 <sub>5</sub> , H <sub>SYNC</sub> , V <sub>SYNC</sub> , X <sub>CIN</sub> , RESET	$V_{CC}=5.5V$ $V_O=0V$			5	$\mu A$
$V_{RAM}$	RAM retention voltage	At stop mode	2.5		5.5	V
$I_{CC}$	Supply current	$V_{CC}=5.5V$ , $f(X_{IN})=4MHz$				
		At system operation and CRT display off		5	10	
		$V_{CC}=5.5V$ , $f(X_{IN})=4MHz$				
		At system operation and CRT display on		7	14	mA
		$V_{CC}=5.5V$ , $f(X_{IN})=4MHz$				
		At wait mode		1		
		X <sub>IN</sub> =X <sub>OUT</sub> stop f(X <sub>CIN</sub> )=32kHz	$V_{CC}=5.5V$	60	200	
		At system operation	$V_{CC}=3V$	25		
		X <sub>IN</sub> =X <sub>OUT</sub> stop f(X <sub>CIN</sub> )=32kHz	$V_{CC}=5.5V$	25	100	
		At wait mode	$V_{CC}=3V$	5		$\mu A$
		At stop mode	$V_{CC}=5.5V$	1	10	
			$V_{CC}=3V$	0.6		

Note 1 : Pull-up transistor is mask option.  
2 : Hysteresis of X<sub>CIN</sub> is only when this port is used as timer 4 input.